



ST. XAVIER'S COLLEGE, JAIPUR

DEPARTMENT OF COMPUTER SCIENCE

PRESENTS



INFORMATICA

PROGRAMMING

TECH

AI

ML

APPS



FUTURE

*Xavier's Student Journal of Computer Science
and Technology*

VOLUME - III , JUNE 2020

EDITORIAL BOARD

Chief Patron

Rev Fr Dr A Rex Angelo SJ

Principal, St Xavier's College, Jaipur

Advisors

Rev Fr Dr Sherry George SJ

Vice Principal, St Xavier's College, Jaipur

Rev Fr Dr Raymond Cherubin SJ

Vice Principal & Administrator, St Xavier's College, Jaipur

Dr Vaishali Singh

Head, Department of Computer Science, St Xavier's College, Jaipur

Editors-in-Chief

Dr Madhu Sharma

Assistant Professor

Department of Computer Science

St Xavier's College, Jaipur

Ms Keren Lois Daniel

Assistant Professor

Department of Computer Science

St Xavier's College, Jaipur

Student Editors

Bhavya Jain

Student, BCA III

Department of Computer Science

St Xavier's College, Jaipur

Priyanka Chandnani

Student, BCA III

Department of Computer Science

St Xavier's College, Jaipur



INFORMATICA

(Xavier's Student Journal of Computer Science and Technology)



Department of Computer Science

ST. XAVIER'S COLLEGE, JAIPUR

Affiliated to the University of Rajasthan

Approved under Section 2(f) and 12(B) of UGC Act, 1956

A Christian Minority Educational Institution under Section 2(g) of NCMEI Act, 2004

Nevta-Mahapura Road, Near Nevta Dam, Tehsil Sanganer, Jaipur-302029

College Website: www.stxaversjaipur.org

Informatica Web page: <https://stxaversjaipur.org/informaticas.aspx>

EDITORIAL TEAM



Left to Right: Dr Madhu Sharma, Priyanka Chandnani, Bhavya Jain, Ms Keren Lois Daniel

“The common facts of today are yesterday’s research.”

Keeping this in mind the Department of Computer Science came up with the third volume of Informatica.

In Informatica there are many articles related to the field of technology which will not only enhance your knowledge but also give you some new tech cognizance.

In this time of COVID-19 it was quite hard to complete this magazine but through the immense support of our faculty editors Ms Keren Daniel and Dr Madhu Sharma, it was all possible. They gave huge amount of time and attention towards this magazine.

We would also like to thank the entire computer department and college management for their precious time and effort.

At last, we would like to thank the authors who submitted their research in Informatica. We hope this journal will give you some amazing knowledge as you flip through it.

Bhavya Jain
Priyanka Chandnani
Student Editors, BCA III, Department of Computer Science, St. Xavier's College, Jaipur

MESSAGE



Rev Fr Dr A Rex Angelo SJ **Principal**

St. Xavier's College, Jaipur

“Research is to see what everybody else has seen and to think what nobody else has thought.”
- Albert Szent-Gyorgyi

St Xavier's College – Jaipur takes great pride in announcing the release of the Third Volume of the Journal, '**Informatica**' released by Department of Computer Science which has made a tremendous progress in promoting excellence in modern education and research publications of students and faculty. With this release, I am sure that it will be an add-on to the enriched catalogue of our college publications and academic literature.

I would like to congratulate the students whose papers are published in this issue and also encourage others to contribute their research papers for significant research in

technology and a road map to unravel the knowledge that is yet to be accomplished in this digital era in the successive issues of the journal

Congrats for this effort and best wishes for your future endeavours!

MESSAGE



Rev Fr Dr Sherry George, SJ **Vice Principal**

St. Xavier's College, Jaipur

Albert Einstein said, “Education is not about learning of facts but training young minds to think.” There is a big difference between cramming up facts and learning them so that they can be applied in productive ways in research. At Xavier's, we try to work towards holistic development of our students by providing them the tools and experiences that encourage our students to think beyond. It is a matter of great pride that Department of Computer Science, St. Xavier's College, Jaipur has come out with its third issue of Informatica. Our college is growing fast as a leader in higher education with its varied programmes and activities focusing on research areas to generate ideas and reinforce them in our society.

My warm greetings and felicitations to all students who have submitted their research

papers for the research enhancement of all. I am sure Informatica will ignite a light to others to grow more in research.

MESSAGE



Rev Fr Dr Raymond Cherubin, SJ

Vice Principal

St. Xavier's College, Jaipur

It is quite gratifying to note that the Department of Computer Science is publishing the 3rd Volume of its Department Journal –'Informatica'. At the outset I would like to congratulate the department for this wonderful initiative.

The changes in the world scenario have been broadly affected by the global pandemic which has brought disruption to our education system and the way of life on a scale previously unknown in peacetime, fear for our health and the health of those around us, grief to those who have lost loved ones.

The purpose of the 3rd Volume of its Department Journal –'Informatica', I suppose, is to provide a forum to committed academicians, researchers, scholars, and

students not only from our college, but also from across the country to deliberate and disseminate the scientific concepts in computer science, theories and models and also to share their research and life management and administrative experiences as well as expertise in handling the crisis which has compounded the global community hardships.

I extend my best wishes to the entire team for their laudable efforts and also wish them success, a grand success for the 3rd Volume of its Department Journal –'Informatica'

MESSAGE



Dr Vaishali Singh

Head of the Department

Assistant Professor

Department of Computer Science

St. Xavier's College, Jaipur

The present situations we live in are unknown to us all and they bring a lot of uncertainties and new challenges. For this reason, Department of Computer Science, St. Xavier's College, Jaipur would first like to express our gratitude to all on behalf of staff and management for all that support we have received from everyone so far for all students on and off-campus.

It is with great pride, enthusiasm, and anticipation that I invite you to read the Volume III of- ***“Informatica- Xavier's Student Journal of Computer Science and Technology”***. The rising progression of digitization has brought with it both boons and banes during the COVID-19 pandemic for future historians. It is very important that the student researchers with the educators unite and collaborate on issues which confront society today. Informatica attempts

to document and spark a debate on the research focused on technology in context of emerging geographies. Informatica strives to showcase a broad range of research conducted by students, thus providing a forum in which individuals from the diverse fields can learn about interdisciplinary research.

I hope that by providing opportunities for undergraduates to have their research published, we can continue to foster their pursuit of knowledge and engage their investigative spirit. I would also like to thank the students who submitted their work for publication. We are certain that the research featured here sets up many new milestones.

Happy reading!

MESSAGE



Dr Dharmveer Yadav

Assistant Professor

Department of Computer Science

St. Xavier's College, Jaipur

St. Xavier's College, Jaipur is known for its excellence and emphasis on high standards of research work. The Department of Computer Science imparts technical education to students to make them globally competent in this digital and challenging world. The chief objectives of the Department of Computer Science are to train and inform students in the field of technology and furnish them with practical knowledge in order to face the challenges of the computing industry. The prime aim of the Department of Computer Science is to prepare students for a technologically driven market. The aim behind publishing the 'Informatica-2019-20 student journal is to provide awareness about technological innovations and to provide a platform for the students to demonstrate their creative ideas

and to enhance their skills in the IT field.

I congratulate the Department of Computer Science for contributing their innovative and constructive ideas to sixth edition of department Magazine "Informatica 2019-20".

MESSAGE



Ms Arpita Banerjee

Assistant Professor

Department of Computer Science,
St. Xavier's College, Jaipur

Research is a common activity which is required in all disciplines and pursuits to match pace with the ever changing world. It has the power of finding solutions to the real life's problems in a systematized and formalized manner, which further sets the model for the rest of the world.

The Department of Computer Science always aims to provide opportunities to the students to explore their potential in research and development along with their academic pursuits. To fulfil the objective of imparting practical knowledge and utilizing it in the field of research and invention, the Department of Computer Science has introduced its third Volume of

the department Journal, Informatica 2019-20. This Students' Journal is surely going to excel the research spirit of our students.

I would like to congratulate the entire department, editorial team and the budding researchers who have contributed their papers in this Journal.

Best wishes for the wonderful efforts!

MESSAGE



Ms Keren Lois Daniel

Editor-in-chief, Informatica 2019-20

Assistant Professor

Department of Computer Science,
St. Xavier's College, Jaipur

It is our honour to inform you all that Department of Computer Science, St. Xavier's College Jaipur is providing its third edition of student journal 'Informatica'. 'Informatica' is a research journal which tells about technologies that can be enhanced and used in the coming years. This journal focuses exclusively on research work carried in creating a live project for their final year by the computer science students. Through 'Informatica', students of computer science department come together to showcase a broad range of technological innovations in their research papers.

This edition has twelve research papers created for real-life computational that serves for the society. To resolve the issues of humanity the students have developed

various applications to showcase their cogitative and learning functions. In this situation, the mission of this journal is to foster a wider understanding of the unifying challenge and to develop a roadmap to solve it. Both mature and new cutting-edge research is welcomed by the journal, provided they have a strong emphasis on concrete empirical or theoretical studies.

I would like to extend our thanks to the students who have submitted their work for publication. I hope that the papers in this journal will provide abundance of information to readers and encourage the students to explore the field of research.

Thank you!

MESSAGE



Dr Madhu Sharma **Editor-in-chief, Informatica 2019-20**

Assistant Professor

Department of Computer Science,
St. Xavier's College, Jaipur

St. Xavier's College, being an internationally reputed educational institution, marks its presence in the world of higher education with the aim of creating men and women with competence, character, and compassion. At St Xavier's, learning is not for a living, but for life. The College believes that, by promoting the intellectual, emotional, and moral growth of all our students irrespective of their caste, colour, and creed, we can create 'men and women for others', committed to and capable of promoting a humane and just world.

The college offers an n-dimensional platform to the students to hone their skills on multiple planes of the education system. With the motive of giving a fair opportunity and freedom to grow and learn, not through us but along with us, the department of Computer Science has offered its Third Volume of the Department Students' Journal

Informatica 2019-20. The Journal has given opportunity to the students of Bachelors of Computer Applications to present their research and innovative aptitude.

It's a matter of immense pride that the students have contributed their research papers with the utmost dedication and hard work. I would like to thank all the authors and student editors and congratulate them for their achievement and advancement towards the excellence in the field of research and development.

Thank you!

PREVIOUS YEAR PUBLICATIONS

Research Papers Published in Informatica-Volume 2, November 2017

1. Augmented Reality: An Overview
Harshi Sharma, BCA III, Student, St. Xavier's College, Jaipur
2. A Review of Uses and Working of Wireless Mesh Network,
Kasvi Khandelwal, BCA II, Student, St. Xavier's College, Jaipur
3. E-Commerce Services in India: Prospects and Problems
Nitin Goyal, BCA III, Student, St. Xavier's College, Jaipur
4. Wireless Networking: History, Working and Impact
Raghav Singh Chaturvedi, BCA II, Student, St. Xavier's College, Jaipur
5. Artificial Intelligence: Boon or Doom
Roopak Bhama, BCA III, Student, St. Xavier's College, Jaipur
6. Retinal and Iris Biometrics
Sakshi Kaur, BCA III, Student, St. Xavier's College, Jaipur
7. Self Driving Cars: The Evolution of Automobile Industry
Shakti Singh Rathore, BCA III, Student, St. Xavier's College, Jaipur
8. Humanoid Robot: The Future Person in The Real World
Shubham Bagdi, BCA III, Student, St. Xavier's College, Jaipur

Research Papers Published in Informatica-Volume 1, December 2016

Section A- Frontiers of Digitalization (2016-17)

1. Virtual Reality
Bhoomi Chaplot, BCA II, Student, St. Xavier's College, Jaipur
2. Digital India: The Future of India
Harshi Sharma, BCA II Student, St. Xavier's College, Jaipur
3. Social Media – A Thrust on Society
Saksham Prabhakar, BCA II Student, St. Xavier's College, Jaipur
4. Digital Locker
Sahil Mehta, BCA II Student, St. Xavier's College, Jaipur
5. Network is Network
Bhavi Bafna, BCA II Student, St. Xavier's College, Jaipur
6. Digital Art
Roopak Bhama, BCA II Student, St. Xavier's College, Jaipur
7. Social Media: Blooming Effects of Internet
Varun Sharma, BCA II Student, St. Xavier's College, Jaipur
8. Digital India
Raj Kumar Yadav, BCA II Student, St. Xavier's College, Jaipur
9. Blooming effects of social media on society
Vaibhav Mathur, BCA II Student, St. Xavier's College, Jaipur
10. Li-Fi -The future technology in Wireless Communication
Shubham Bagdi, BCA II Student, St. Xavier's College, Jaipur

11. Digital Lockers - Role of E-Lockers
Diksha Joshi, BCA III Student, St. Xavier's College, Jaipur
12. Leveraging Digital Skills for Innovation in Society
Vaibhav Gupta, BCA III Student, St. Xavier's College, Jaipur
13. Security Issues in E-Commerce
Sarathak Jain, BCA III Student, St. Xavier's College, Jaipur

Section B- Frontiers of Securities Aspects (2015-16)

1. Current Scenario of Web Development/Blogging in India
Akshay Singh Shekhawat, Ritesh Saini and Vaishali Singh
2. Security Requirements: Non-Repudiation Attributes
Diksha Joshi and Vaishali Singh
3. ICT impaction in Teaching and Learning (Perspective: School Education in India)
Radhika Bihani and Vaishali Singh
4. Cloud Education in India: Low Rate Adoption
Jayant Khushalani, Surya Pratap Singh and Dharmveer Yadav
5. Effects of Social Media On Our Lives
Radhika Bihani, Ritesh Saini and Vaishali Singh
6. Non-Repudiation- An Emerging Security Requirement of Cloud Computing
Ishita Gupta and Vaishali Singh

Section C- Frontiers of Cloud Technology (2014-15)

1. Cloud Computing Threats
Adhiraj Wilson Nathaniel and Vaishali Singh
 2. Cloud Computing Enhancing Indian Education
Harshit Prakash and Dharmveer Yadav
 3. Security Issues in Social Networking Sites
Pallavi Sharma and Arpita Banerjee
 4. Non Repudiation: Security in Cloud Computing
Diksha Joshi and Vaishali Singh
 5. Problem Faced By Indian Education in Cloud
Sarathak Jain, Dharmveer Yadav and Prof. D. P. Sharma
 6. Software Maintenance: Challenges and Issues
Aakriti Gupta and Shreta Sharma
-

TABLE OF CONTENTS

S NO.	TITLE AND AUTHOR	PAGE NO.
1	Gym Management System <i>Mahesh Thapa</i>	13
2	Women Warrior: A Mobile Based Safety System <i>Garima Modi, Sakshi Wadhvani</i>	19
3	E-assistance for Maid Services <i>Lakshay Agarwal, Rohan Singh, Sharan Shibu</i>	25
4	SMS: Augmenting the School Practices Effectively <i>Sahil, Blessy</i>	30
5	Blood Donate Mobile Application <i>Kriti Malpani, Manisha Shresth</i>	35
6	Payroll Management System <i>Varun Nandwani, Jagpreet Muchhal, Pushpendra Achora</i>	44
7	Jewellery Design and Management System <i>Komal Khatri and Ashpreet Singh</i>	48
8	Foody funday: A Restaurant Management System <i>Abhinav Sharma, Chhavi Prakash Saxena, Kalika Bargota, Samerth Sharma</i>	53
9	Collision Prevention and Avoidance Mechanism <i>Ranvijay Singh Tawar, Daksh Mathur, Dishant Sharma, Banu Pratap Singh</i>	59
10	Kudrat: A Real -time Anonymous Communication System <i>Angad Srivastav</i>	70
11	Hostel Management System <i>Umang Choudhary, Bijoy K D, Yash Sonkiya, Aryan Sharma</i>	75
12	Online Book Rent System <i>Amandeep Singh, Deepank Jangid, Shresth Bhatiya</i>	79

Gym Management System

Mahesh Thapa

Student, BCA III, Department of Computer Science

St. Xavier's College, Jaipur

Abstract:

Websites play a major role in today's electronic world. Having a website means availability of information of particular business to the user. Websites is a nifty tool that every business need. For this reason, an online system, i.e. a website is required for a gym owner, where customer can get all information about the gym and can register themselves, has been introduced and developed. Usually, Managers or staffs use paper or register for maintaining their records. There is lot of redundancy of work and chances of errors. Also, when the records are changed, they need to be updated every time on every file. The Gym website consists of Gym management System which eliminates most of the limitations of the existing system. The gym website increases efficiency and effectiveness, automation, accuracy, user-friendly interface, information availability, communication capacity, maintenance, cost reduction makes our system smarter than the existing system. The system has been introduced with some new features along with all the necessary and basic requisites. Some of them are like receiving details from client as well as entering of data by admin/receptionist, searching of details of client or trainer by id or their name, deleting the details of client and trainer.

Keywords: *Gym management, php, database, platform-independent, MySQL.*

I. Introduction

The proposed “Gym Website and management system” is for those who run a gym business. Before designing this website, a research based study was conducted to derive the difficulties or challenges faced by the gym owners to maintain the records. With the help of the study, database design was developed. The ease and reliability of system's functionality were focused while the execution of the registration process [1]. The gym website provides information to the users related to all the facilities present in gym, Training schedule, types of training and transformation information of the clients.

The gym owners require software to maintain a record of client, staff and trainers. The system provides data storing & report generation of trainers and client's information. [2] This system not only evaluates all the information of each and every member but it also gives us to future updating and also this system showing a messaging system where user can easily understand about it [3].

II. Literature review

An existing system refers to the system being followed till now. The gym management is completely manual. It is a time consuming system and costly, because it involves a lot of paperwork [1]. Manual handling of the system is not an easy task, because the manual records maintenance is a time consuming activity with the involvement of lot of paper work and maintenance of data in registers [4].

Use of files and registers are used for storing data which increases the storage space [5]. Use of paper for storing a data is difficult for staff, as they need to update the system manually if some error occurs. It is not easy to keep the information confidential in paper form. These can cause errors in calculating mechanism or maintaining customer and trainers details [2]. It takes time to make new entries.

The following are the reason why current system should be computerized:

- To increase efficiency with reduced cost.
- To reduce the burden of paper work.
- To save details of each and every member and employee.
- To generate report easily.

III. Proposed framework

The proposed system is the Website designed using (front end) HTML, CSS, Bootstrap and (back-end) PHP, and is user friendly website [6] [7][8].

The system proposed has many advantages.

- The proposed system is secured with login id and password.
- It provides wide range of menu in each window helping the trainer as well as client for quicker solution.
- It can give calorie requirement details to the client helping them to achieve their fat loss or weight gain goals.
- It maintains report for all the trainers and clients.
- Manages member information separately.

This system can run on any windows operating system

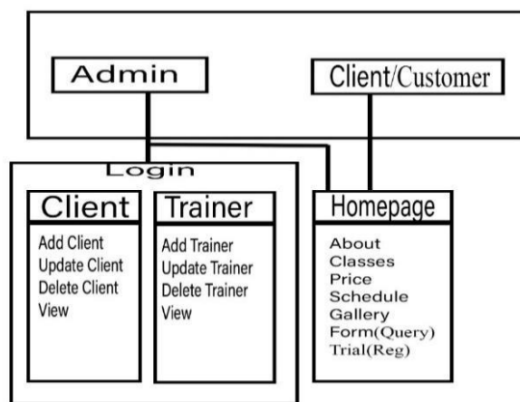

Fig 1. Website framework

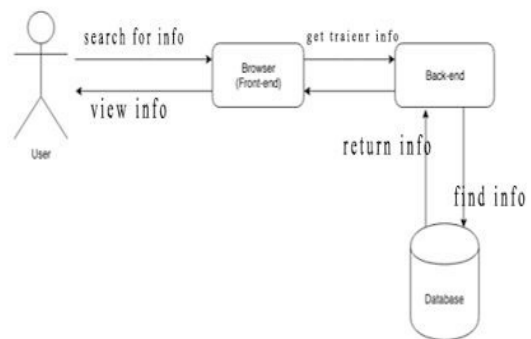

Fig 2. Front-end and backend diagram

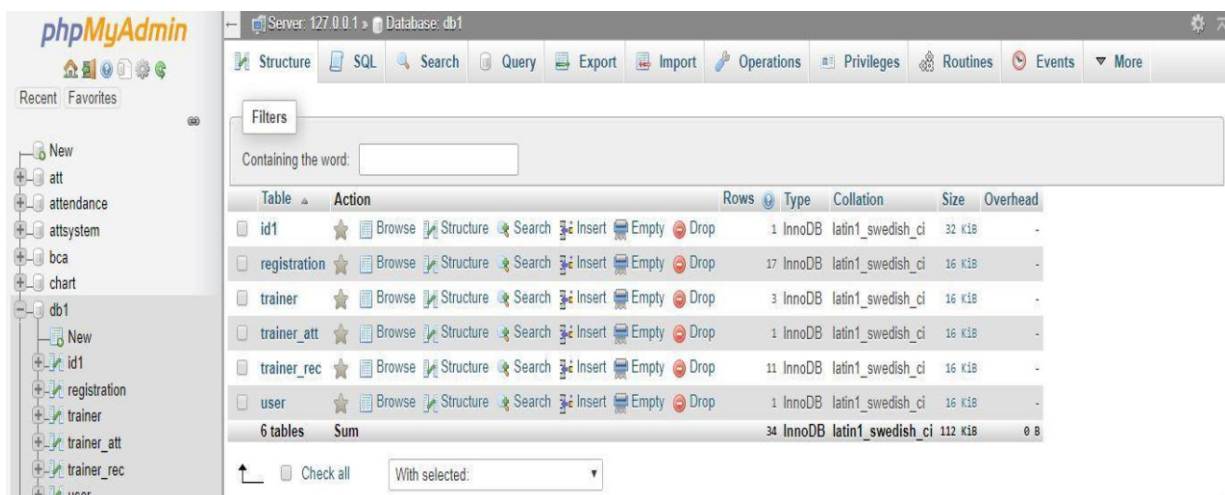

Fig 3. Mysql database

I. Login: Admin is the authenticated user and is provided with a username and password. Admin after logging in is redirected to the admin pages i.e. admin dashboard. The normal users are not allowed to access the website.

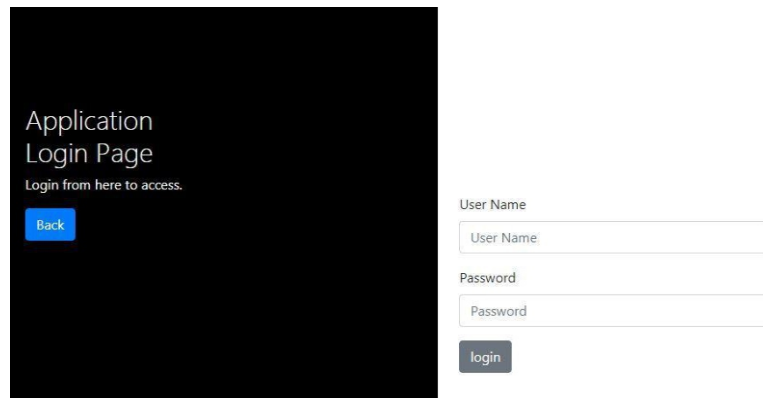

Fig4. Login for admin

II. Gym Member client portal: Whether running a small gym or a large chain of gyms, marketing the fitness club is one of the most important parts of running the business. People who want to get gym membership can easily register them for membership. This plays an important role for all the gym owners, as it helps in increasing their customers.

III. Contact form: Contact forms helps reassure customers that there's someone listening to complaints and feedback. Making it easy for customers to contact the owner or admin if something goes wrong.

IV. Report Generation: The System is capable of generating a report of client's data and trainer's data stored in the database. The report generated in the form of pdf can be shared easily [9].

There are four basic modules of the proposed system as described below:

- a. Dashboard: The dashboard module is necessary for managing all the task and can be accessed only by admin. Dashboard module carries the following function:
 - Quick view of important Gym Modules
 - Different report for management
 - Quick view of total trainers and client.

- b. Trainer module: The trainer module is necessary for managing all tasks related to the trainer. Trainer module carries the following function [10]:

Add new trainer	Update trainer data
Delete trainer	Generate trainer report

- c. Client module: The Client module is necessary for managing all tasks related to the trainer. Trainer module carries the following function

Add new Client	Update Clients data
Delete Client	Generate Client report

- d. User module: Interface that grants user's access to features of this system [11].
Functionality of user module includes:

- Applying for membership
- Enquiry to authority

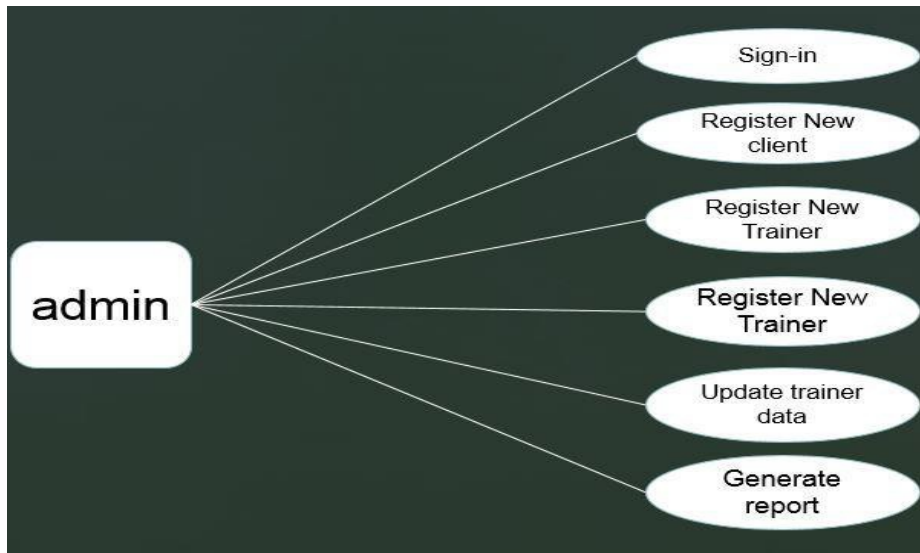

Fig 5. Use case diagram for admin

IV. Feasibility study report

The feasibility of the report can be considered in terms of technical factors economic factors or both. The proposed gym management software includes the following analysis-

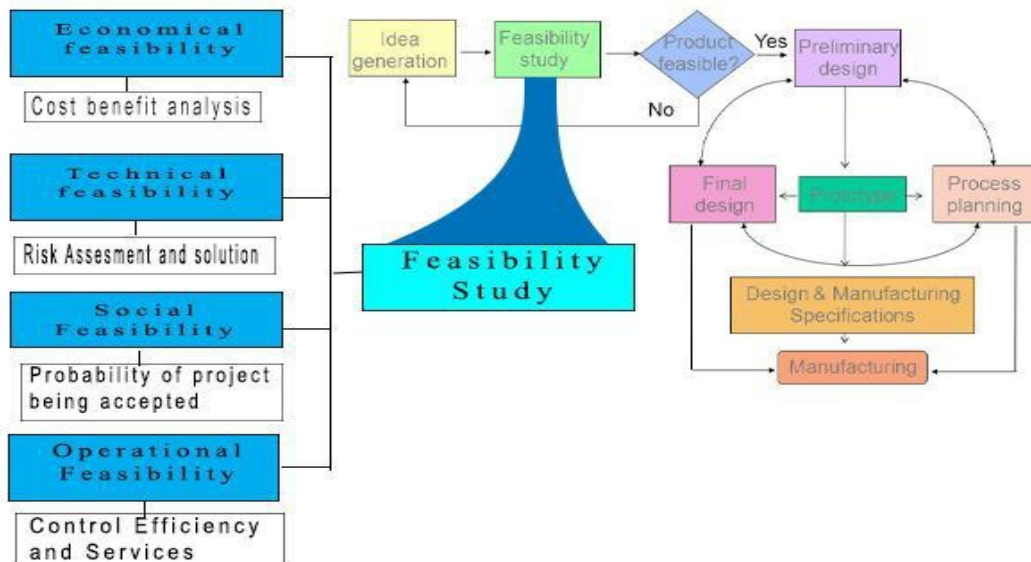

Fig 6. Design process and Feasibility review diagram

- **Technical feasibility:**

At first it's necessary to check that the proposed system is technically feasible or not & to determine the technology and skill necessary to carry out the project. If the system are not technical feasible then find the solution to make the system feasible. All the required Hardware component is already available in the college.

- **Economic feasibility:**
Economic feasibility is related to the system performance, information and outputs from the system. The website is made using Html and CSS which requires technical knowledge. The cost incurred to develop the system is less & does not incur the cost to the project. Backend database used is PHP which is a freeware. This justifies economic feasibility of the system.
- **Social feasibility:**
System is fully designed to reduce the workload of the user. System helps the user to perform operations like inserting data of trainers, employee and generating reports with less possible errors. Thus, there is no reason to make system socially unfeasible.
- **Operational feasibility:**
The operational feasibility is obtained by gathering information from the user. The study involves checking whether the proposed solution satisfies the needs of user or not. The clients as well as trainers can easily update data according to their need. The existing system is manual file management system while the new system is computerized and extremely user friendly.

Cost and Benefit analysis

Cost Estimation	Benefit Analysis
Cost required for the project is to install the software and hardware requirements. Software may include installing Xampp as local server [12]. Website can also be hosted on server which can increase a cost. Cost due to the time taken for completion of the project which can be around 2 months.	Due to the introduction of this system the cost of handling the system is reduced. The cost includes maintenance cost, purchasing books and files cost. In order to reduce the cost, new system was proposed. The newly proposed system provides easy storage of data and retrieval of data. The new system is fully automated.

V. Future work

The software is user friendly and any future changes can be done easily. All the efforts have been made so that the projects can easily be executed and improved according to the needs. The following are some of the enhancement that can be added to improve the project.

Application of the project can be done more attractively. Database management and all the modules can easily be managed by the admin. Systems can be made flexible by integrating some of the useful features for e.g., security features can easily be implemented. Below are some of the useful points that can be consider:

- Fitness suggestion by enquiring the health Condition.
- Automated chat system.
- Online video conferencing for trainers.
- Online payment through face recognition.
- Barcode generation for new members and member can take entry to Gym using membership card.
- Biometric scanner for entry attendance.
- Attendance management.

VI. Conclusion

The “Gym Management System” is designed to fulfil all the needs of the customer as well as Gym managers. The system designed is user friendly, form validation and field validation works very efficiently. The new computerized system is much faster than the old system, and system is designed and tested successfully. It provides ease in calculation and storing of data, thus reducing the chances of human errors. The information stored in the database can easily be accessed by the admin. Fully automated machine has reduced the staffing as well as paper cost. The newly proposed system reduces the burden of manually updating of data.

References

- [1] M. A. Sambare, D. Bondre, S. Thorat, M. A. Vishe and P. A. Sanghavi, "Gym Monitoring Framework for Fitness," International Journal of Advanced Research in Computer and Communication Engineering, vol. 6, no. 3, 2017.
- [2] K. Mahima, R. Pooja, W. Niyati and G. Lodha, "Survey Paper on Gym Management System," Journal of Advancement in Software Engineering and Testing, vol. 2, no. 3, 2019.
- [3] M. M. Rahman and M. Basirat, "Gym Management System," Daffodil International University, 2018.
- [4] M. Ahmed and J. Nayeem, "A Project Paper on Smart Gym Management," 2016.
- [5] I. Khaghani-Far, S. Nikitina, M. Báez, E. A. Taran and F. Casati, "Fitness Applications for Home-Based Training," IEEE Pervasive Computing, vol. 15, no. 4, pp. 56-65, 2016.
- [6] F. Cassolaa, L. Morgadob, F. d. Carvalhoc, H. Paredesa, B. Fonsecaa and P. Martinsa, "Online-Gym: a 3D virtual gymnasium using Kinect interaction," Procedia Technology, vol. 13, p. 130 – 138, 2014.
- [7] "tutorialspoint simply learning," [Online]. Available: <https://www.tutorialspoint.com/php/index.htm>. [Accessed 12 July 2020].
- [8] R. Nixon, Learning PHP, MySQL, JavaScript,, O'Reilly Media, Inc, 2014.
- [9] "fpdf," [Online]. Available: <http://www.fpdf.org/en/script/script21.php>. [Accessed 10 July 2020].
- [10] "tutorialspoint simply learning," [Online]. Available: <https://www.tutorialspoint.com/sql/index.htm>. [Accessed 12 July 2020].
- [11] "interaction design foundation," [Online]. Available: <https://www.interaction-design.org/literature/topics/ui-design>. [Accessed 12 July 2020].
- [12] "Apache friends," Apache, [Online]. Available: <https://www.apachefriends.org/download.html>. [Accessed 14 July 2020]
- [13] M. R. Girnale, K. D. Untwal, S. S. Jathar, P. Anand and M. Bhonsle, "Virtual Gym Management System," International Journal of Engineering Technology Science and Research, vol. 4, no. 11, 2017.

Women Warrior: A Mobile Based Safety System

Garima Modi, Sakshi Wadhvani

*Student, BCA III, Department of Computer Science
St. Xavier's College, Jaipur*

Abstract

In today's generation, the volume of people using smartphones is increasing continuously. Thus, it has opened scope for various types of applications for user convenience. With all those, a smart phone can also be used for personal security or various other protection purposes, mainly for children and Women security. In general, majority of crimes are committed with women or girls. Thus, the development of a security system is needed for women safety on high precedence. The proposed system-Women Warrior, a mobile based application might help in reducing such crimes. This security system has been designed for women in distress. This application can be activated by a single click, which then sends the location of the user and sends a message and connects a call to the registered contacts. The unique feature of the application is an Alarm button from which an alarm sounds by a click and victim can seek help, in case of absence of inter network. Safety tips and laws are also there. With the registration and logging in to the application with the correct information, the user's life can be saved. All these features of the application combine all-in-one system for women safety.

Keywords: *Android Application, GPS Tracker, Emergency Alarm, GSM Module, Safety Tips*

I. Introduction

Women safety is one of the prime concerns everywhere in the world, where women are playing an outstanding role in each and every field. However, a few incidents happened recently alerts the society and indicates that there is an urgent need to introduce aids and measures for women safety. Very often, women don't feel safe while going outside alone due to increasing number of cases of violence and rape cases against women[1][2]. This, paper presents a system that is capable of providing more security and safety to women. "Women Warrior" is a security system, which has been designed for women in emergency and in distress. The prime objective of the system is to provide fastest and simplest way to contact a nearest help. The basic approach with a single click is to intimidate the instant location and a distress message to the pre-set numbers, so that unfortunate incident can be averted. This can also help police department to reduce the crimes, which are against women and the evidence can be used to trace the crime.

II. Literature survey

The status of women in the world has gone through many great changes over the past few decades. However, women in India continue to face social challenges and violent crimes. In 2013, a brutal gang rape in a bus in New Delhi witnessed the level of insecurity against the women. Another incident that took place at Mumbai, while a lady who was leaving her native place after Christmas holidays, got kidnapped and killed. According to the NCRB, in India, 93 women were raped every day. Also 3, 37,922 cases of crime against women were reported alone. But rights workers say that the Figs are likely not an accurate representation of the

scale of the problem, as stigma surrounding sex crimes means many attacks are not reported. Kavita Krishnan, secretary of the All-India Progressive Women's Association, warned that the Figs should be analysed with caution. As a part of literature survey, few of the applications that offer the same or similar services for android and other platforms, were investigated [1][2][3][4][5][6][7][8][9][10][11]. The aim is to see how these applications work and to see how they can be improved. These apps are as follows –

- Fightback: - This app is developed by Mahindra faction. This app sends alert message with the help of services like- GPS, SMS, Location maps, GPRS and with Social Networking websites.
- Secureme Beta: - This app is developed by Think MPI Consulting Private Limited. It helps the victim to raise alert and provide help in case of life-threatening emergencies.
- Raksha - This app is launched in the year 2014. By clicking on this app, it sends location of the user to the contacts registered and the user can also get the details of the location of the contacts.

III. Proposed system

(a) Hardware and Software Requirement:

- The methodology used in this paper is that the device can be activated by just pressing the emergency icon “HELP” once. This device gets activated and sends instant location with a distress message to the respective family members, who are registered in advance by the user.
- User can also find the current location of itself when they don't know the place.
- User can also use the alarm if there is network problem or internet connectivity problem for help.
- Women related laws and Safety Tips and videos are also there in the application.

System Functionality:

When a user click on the application, a thread, connected with the main page of the app get activated. , the home page consists of simple user interface. Depending upon the problem, the appropriate icon could be selected, which could guide the user during emergencies. When a user click on those icons the related services and utilities like camera, message, call, Safety tips, help message, video recorder, Current Location, get activated.

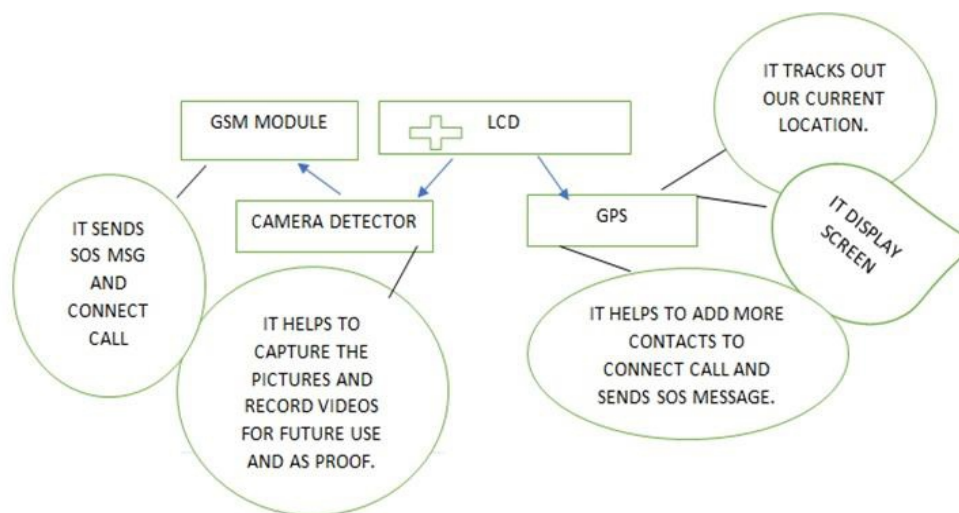

Fig. 1 Block Diagram of the Women Warrior System

(b) System's Key Modules

Location: -Through GPS tracker the location of the user is tracked by the police, for this user only have to turn on the location.

Videos: In the application there is video of techniques to safeguard user.

Help message: This emergency message consists of our current location Tracked and sent to GSM module in which our location and our default emergency message is sent to our pre-stored contacts

Hidden camera: There is a camera icon in the application from which we can click photos.

Voice call: In this application, user can also call directly to anyone for help from their contacts.

Message: In this application, user can also message directly to anyone for help from their contacts.

Alarm: In this application, if there is not internet connectivity, they can use the alarm for help from their limited area.

The proper security system has been developed with different functional modules. Fig. 1 depicts the main screen of the application. By clicking on the shield, we see four options they are “Safety Tips”, “Alarm”, “Safety Techniques”, “Videos”, which are shown in fig.2. Fig. 3 shows the Safety Tips selection module. The safety instructions related video module is as shown in fig. 4. Fig 5 depicts the screen, when Safety Technique is selected. Fig 6 represents the main screen, if the message icon is selected. Fig. 7 represents the screen when user selects a particular contact. Fig 8 depicts the screen when the call icon is selected and depicts the screen when a particular contact is clicked and the call would be initiated. On the main screen, if the camera icon is selected, then it will automatically click pictures. In the navigation drawer, there are six options they are “Login”, “Home”, “Profile”, “Helpline Numbers”, “Laws”, “Current Location” as shown in fig.8. Fig. 9 depicts the screen when user performs login operation. After typing the already saved and registered phone number, if it is registered, then it will open the main screen and otherwise it will respond as shown in fig. 10. Fig. 11 shows the profile module. Fig.12 and fig.13 depicts the update and delete module respectively. Helpline Module is depicted in fig.14. The legal guidance module is shown in fig. 15. Women related legislation module is shown in fig.16 and fig. 17. Current location module is shown in fig. 18. When a user clicks the help button, a help message would be sent to the respective already registered contacts, as shown in fig.19.



Fig. 1



Fig. 2



Fig. 3

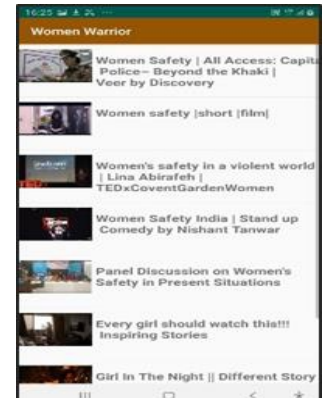

Fig. 4



Fig. 5



Fig. 6



Fig. 7

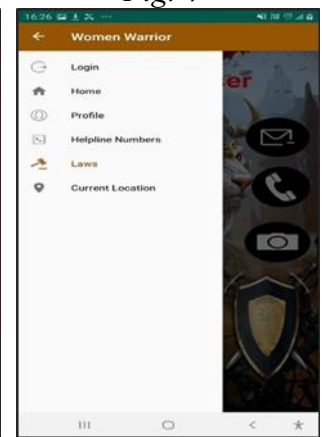

Fig. 8



Fig. 9



Fig. 10



Fig. 11



Fig. 12

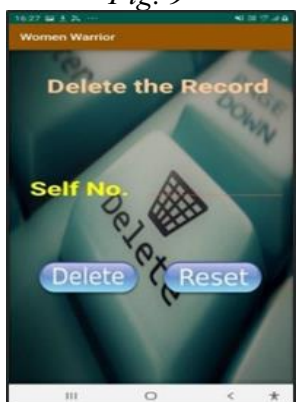

Fig. 13

All India	
Women's Helpline (All India) National Commission for Women	1091/1090
	0111-23219750
Delhi	
Delhi Commission for Women (DCW)	0111-23378044/2337831
Outer Delhi Helpline	011-27034873
Women in Distress	1091
Police Control Room	100
Child Helpline	1098
Anti Stalking / Obscene Calls	1096
Child, student and Senior Citizen	1291
DCP SN Mosobi, North East Special Unit	9818099070
IGP - Robin Hibu, Nodal Officer for Northeastern	9810083486
Andhra Pradesh	
Hyderabad/Secunderabad-Women	040-27853508

Fig. 14

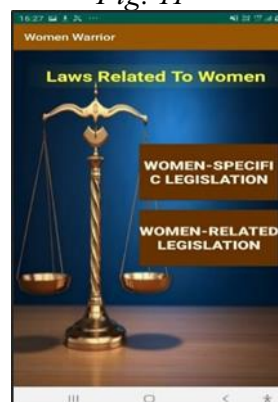

Fig. 15

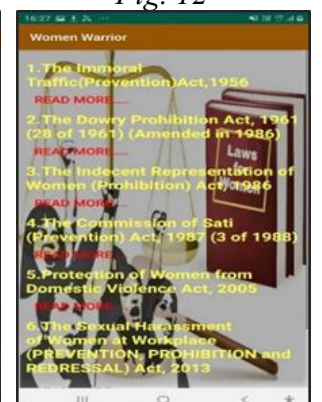

Fig. 16

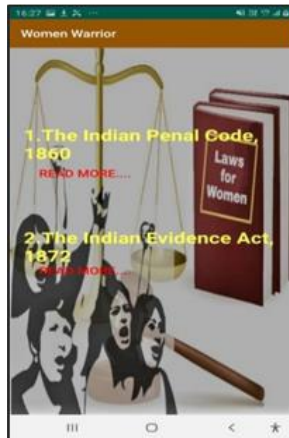

Fig. 17

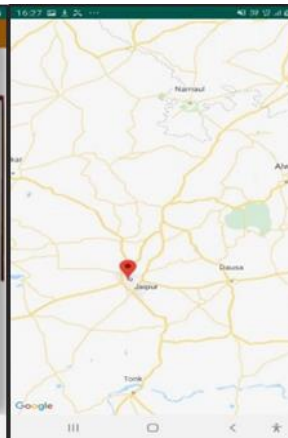

Fig. 18



Fig. 19

IV. Recommendations

The key recommendations w.r.t this app is as follows:

- At first, the user should enter the four contact numbers of police, family members and friends in to the application and click on “save” button.
- While travelling, run the application and whenever need arises, click “start” button.
- As soon as “start” button pressed, it firsts make a call to the first saved registered contact number and also sends the message containing location URL of the victim to all the contact numbers.
- Unique feature of this app is message with location URL is sent continuously to the registered contact numbers for every five minutes until “stop” button is clicked. So, continuous location tracking of victim is possible with this application.
- This mobile application is helpful in future when any problem arises in travelling or any kind of situations.
- With the upgradation in technology, this app is compatible for all related updates and the changes would be adopted by the system.
- With the evolution of technology, and due to upcoming security challenges, system's security would also be improved using emerging technologies.

Advantages

- It is an all-in-one system. Hence no need to carry multiple devices.
- It records audio, video and pictures which can be used for further investigations.
- Alarm is also there when there is problem in internet connectivity.
- It allows calling or messaging directly to other contacts also.

Disadvantages

- There is no camera detector which is portable to ensure the user's privacy.
- Monitoring is tedious.
- Mischance in arriving rate.

V. Conclusion

In this research, an intelligent and sophisticated Women safety system is proposed. The system ensures complete women safety with self –defence during public transport. This mobile application is extremely useful for the women in danger and can execute the app easily in any situation. The “women worrier” mobile app helps in sending alert messages to

their guardians and care takers. It assists in auto dialling of pre saved contact numbers. The Police help is also called with this mobile app with the location information of the victim.

References

- [1]ABHAYA: An android app for the women safety, by Vegan University, department of ECE. A device to help women in distress. Available on Research Gate.
- [2]https://www.researchgate.net/publication/287201587_Abhaya_An_Android_App_For_The_Safety_Of_Women
- [3]FEEME. A device to help women in distress. All in one system of security. An initiative by student D.G.Monisha of University of Chennai Department of Information Technology.
- [4]https://www.researchgate.net/publication/299404936_Women_safety_device_and_application-FEMME
- [5]IJSETR Women safety location tracker used mainly for women safety. Volume 6 issued 8. Available on academic education academia.edu 2017.
- [6]<http://ijsetr.org/wp-content/uploads/2017/08/IJSETR-VOL-6-ISSUE-8-1241-1243.pdf>
- [7]Academic education. An online website for providing study materials for extra information. http://www.academia.edu/Documents/in/Womens_safety
- [8]IJCA International safety system for women security volume 130 in 2015. By Abhijit Partaker engg. Student and Deepak Sharma Assistant professor of K.J. Somiya college of Engg. <https://www.ijcaonline.org/research/volume130/number11/paradkar-2015-ijca-907144.pdf>
- [9]Suraksha. A device to help women in distress: An initiative by a student of ITM University Gurgaon. efytimes.com. 2013. Available from: <http://efytimes.com/e1/118387/SURAKSHA-A-Device-To-Help-Women-In-Distress-An-Initiative-By-A-Student-Of-ITM-University-Gurgaon.pdf>
- [10]Chand D, Nayak S, Bhat KS, Parikh S. A mobile application for Women's Safety: WoS App. 2015 IEEE Region 10 Conference TENCON; Macao. 2015 Nov 1-4. p.
- [11]Pantelopoulos A, Bourbakis NG. A survey on wearable sensor-based systems for health monitoring and prognosis. IEEE Transactions on Systems, Man and Cybernetics – part C: Applications and Reviews. 2010 Jan; 40(1):1–12.

E-Assistance for Maid Services

Lakshay Agarwal, Rohan Singh, Sharan Shibu

Students, BCA III, Department of Computer Science
St. Xavier's College, Jaipur

Abstract

Building on qualitative, unstructured interviews with general housewives of India's informal economy, this article seeks to illuminate the complexity of the domestic work with them and problems in home management faced by them and methods adopted by them as they find the other helping hand in the form of maids. Online Maid Finder is a system which needs to be there in order to help housewives and hence assists in finding the essential personnel for their homes. Using it, one can appoint for different kinds of services which are required in houses, in short for all kinds of household jobs. Using and analysing different platforms, a system is prepared to create the best which suits the best. Here, in this paper, the methods and methodology required for the development of an e-assistance for maid services has been presented.

Keywords: domestic work, informal economy, maids, home management, essential personnel

I. Introduction

Online Maid Finder is a system aimed to help housewives to find the perfect set of persons for their household jobs. If a proper look is given to the base ground for its need, each household has a lot of work for which maids are necessary and a system should be there to help connect the needy and the recruiter.

It will act as an intermediary for the needy persons who need work and the housewives suffering to find the right type of person to help them. As the problem occurs when in some areas there is a lot of deficit in the number of persons who can do household work. Whereas there are some places there are a lot of them but no household for them to work on. Using different programming languages, this platform was designed and developed. When any user will use it they will realize that the navigation is easy and they will have no problem going through it and find what they came searching for. Section II of the paper defines the design of the proposed system, section II focuses on the data confidentiality and the related aspects.

II. System Design

The programming languages, tools and platforms required for the proposed e-assistance for maid services are:

- HTML – for web development
- CSS – for adding style in display and presentation
- Photoshop - (For interface design)
- Mysql – for database design
- PHP – for server side programming
- Xampp – Server

System Modules and functionality:

Key Modules:

- Login Module

- Main Module
- Dashboard
- Registration Module
- City selection Module
- Contact Module
- Data storage Module

Firstly, a user can access the application by entering or registering in the application. After registration, login module is available, which makes a user enter in the 'Online Maid Finder' application. After login, home page is provided. The services and the popular categories which are offered in the system are depicted in fig. 1, where different types of service persons are segregated on the basis of their specialization and the departments they can work in. User can select the category for which a user wants to hire a person.

If user selects, say for example the category-babysitter, then the user would be directed to the select city module, where user would get the option to select the city in which they want to hire someone.

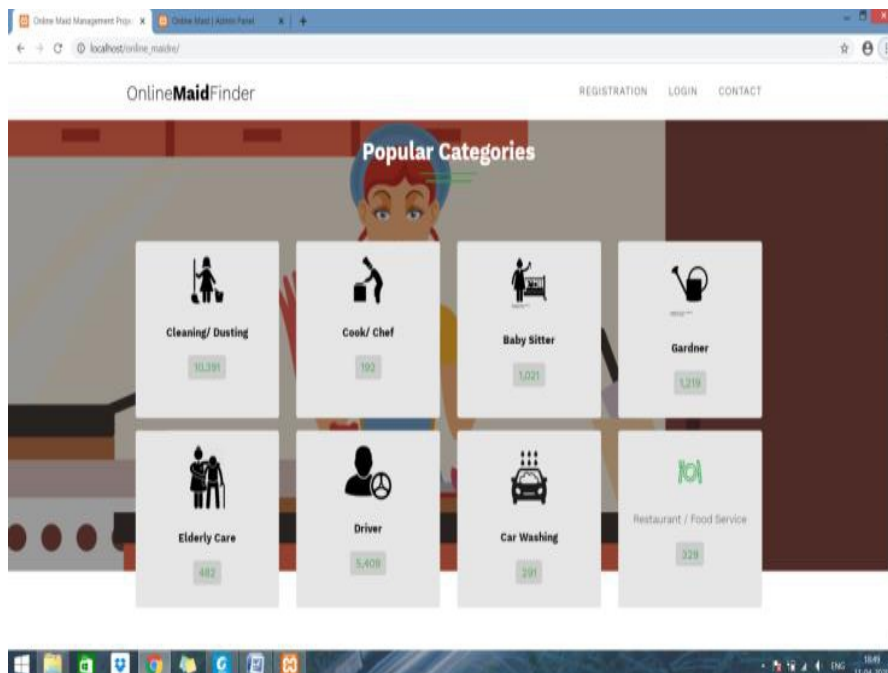

Fig 1. Home page

Once a user selects the city, list module is made available to the user, where the list of eligible candidates for the job in that particular city would be provided. This module is connected with the registration module, as shown in fig. 2. There will be details with photos of every candidate and a user can review each candidate and call the person who suits you and ask to visit you. In this way you will be easily able to hire the correct person for your job.

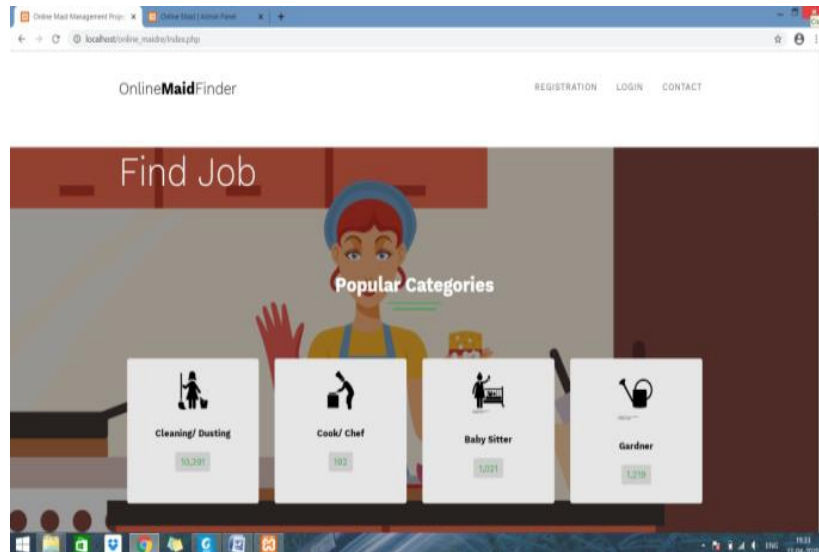

Fig 2. Find Job Page

Now if the user is a worker and want to seek a job in one of the categories, then they have to register themselves and fill out all the details including picture upload. The details aids in getting quick response. The data is stored on the server and then the service provider access the right person for their tasks.

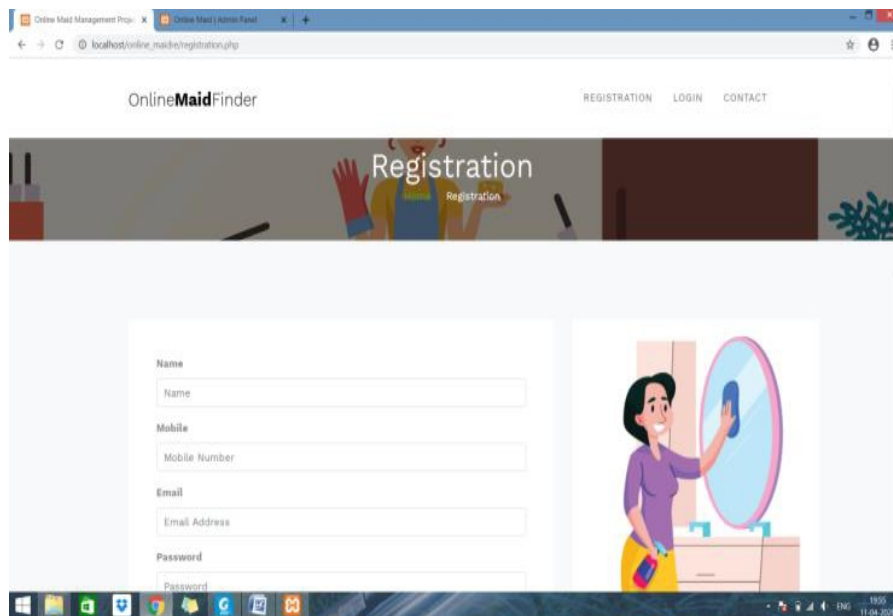

Fig 3. Registration

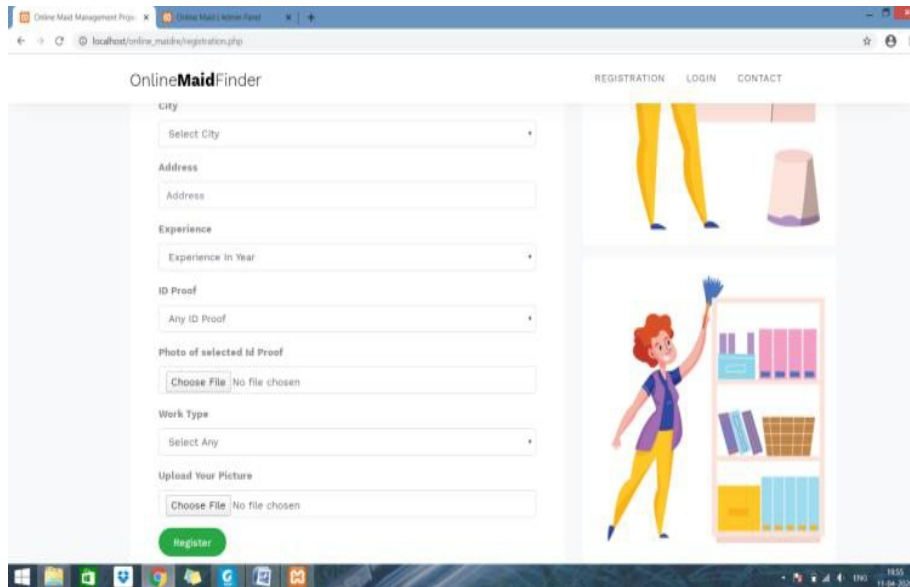

Fig. 4 Registration Details

With strong back support and admin pan el, a user receives al possible support for getting the right job and vice versa.

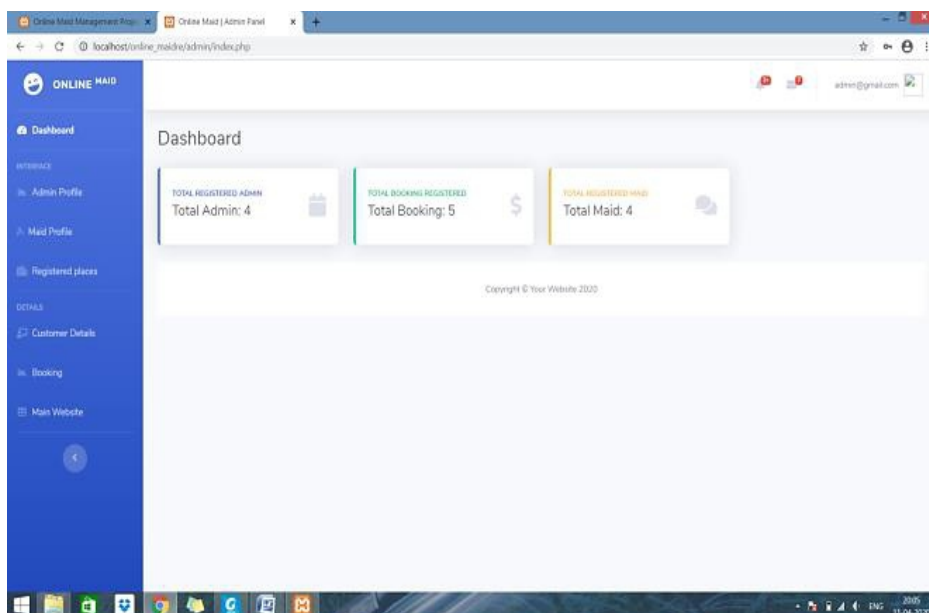

Fig. 5 Dashboard

III. Data Confidentiality

Now, either you want a job or want to do a job, for any information a user can always look out for contact us module. There the user can also see all of the information and can contact through contact us module, after filling out their details.

One of the prime needs of the system's functionality is the data security and the concern is about the data security. Yes, every possible step is taken to keep the user's information

secured. Also the details a user fill will only be viewed and accessed only by system so no information misuse.. Also all technical glitches and gaps which can be used to tamper the information are taken care of. So, there is no problem if the user could surf very safely.

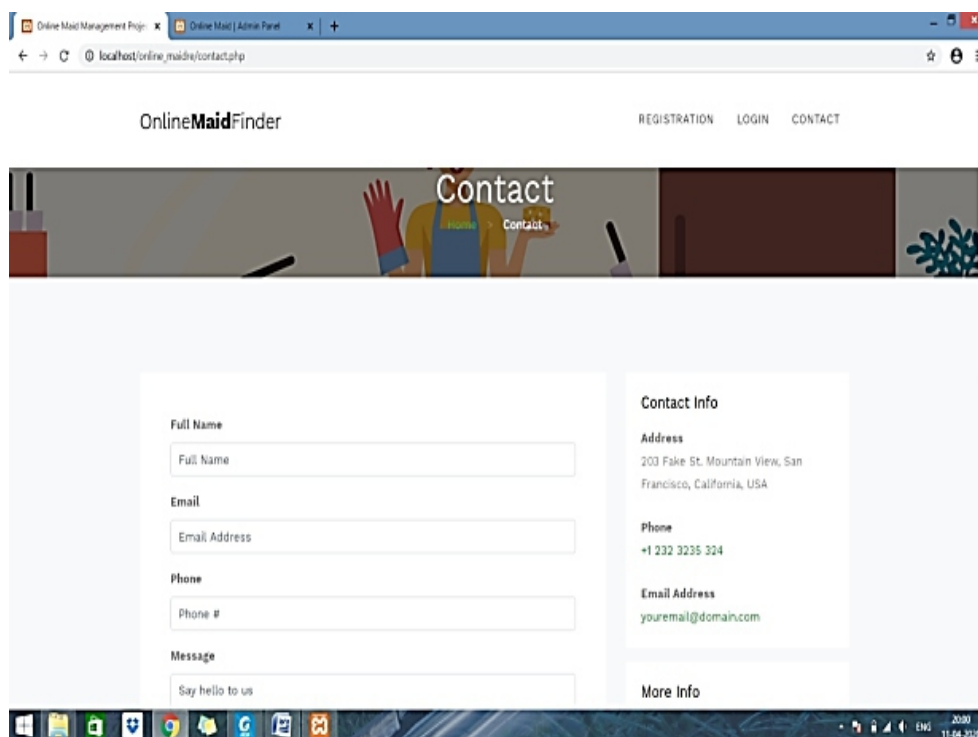

Fig 6. Contact Page

IV. Conclusion

While developing it, the main thing that came out as conclusion is the vast scope in different languages, like all languages i.e. html, css, JavaScript, mysql, php play an important role in making a platform and proper coordination and making correct use of all languages are required for successful completion of a project. Thus, with the support of the system, any person, especially housewives don't have to go here and there in search of their helping hand and they can easily hire required persons through an online maid finder.

References

- [1] Alan Forbes The joy of php Programming: A beginner's guide to Programming Interactive Web Applications with PHP and MYSQL
- [2] Shahrzad Shahriari Mohammaderaza Shahriari Saeid Gheiji : E-commerce and its impact on Global Trend And Market . International Journal of Research.
- [3] www.w3schools.com/php.aspx
- [4] www.learn-php.org
- [5] www.geekforgeeks.com/phpstudy.html
- [6] Rasmus Lerdoff, Programming PHP, O'reilly , 1 Edition, 5 April; 200

SMS: Augmenting the School Practices Effectively

Sahil and Blessy

*Students, BCA III, Department of Computer Science
St. Xavier's College, Jaipur*

Abstract

The advancements in technology have continued to influence society so as to leap towards success. Every technological reform is a small step towards advancement, innovation and progress of mankind through the brilliance of the human mind. Developments in information technologies have also been impacting the educational systems. The introduction of various advanced technologies in schools can thus result in decreased usage of paper and thus, bringing in the e-formal or the digital era. Thus, the schools should employ a management information system (MIS) to improve the efficiency of management services. A school management information system is a system that provides the necessary information to manage a school effectively. They provide an objective system for recording and aggregating information and provide support to the institution's strategic goals and development. The administrative processes and the huge official paperwork of school can be simplified by the means of management information systems (MIS). School records the information about all its students and teachers can be efficiently maintained by means of the school management system. On the similar lines, the assignment and attendance records of the pupils and teachers can be maintained by means of assignment and attendance management system respectively. Further, the management information system can effectively maintain the data pertaining to assignment, finances, books and management of the institutions. To sum up, the school management system not only eases the paperwork but also ensures the efficient functioning of the school's administration. It makes up for a more effective way of storage and distribution of information without any hassle. Therefore, realizing the importance of management information systems in schools and more importantly its successful implementation is a necessity. There is a dire need to employ such systems to bring qualitative improvement in the prevalent educational practices.

Keywords: *School Management system, faculty management system, library management system, attendance management system, financial management system, student management system.*

I. Introduction

Technology has an increasingly significant impact and broad implications for everyone – individuals, institutions and the entire nation. The advanced technologies are more pervasive today than they have ever been and their uses are expanding continually. Information technology is significantly enhancing and altering human activity and enabling us to live, work and think in ways that most of us never thought possible. The explosive growth of computer-based technologies has left a tremendous impact on educational institutions. Since computer – based technologies are continuously evolving and their distribution throughout the education system is constantly changing, responding to the demands for technological data requires the ongoing information gathering to be efficient. Information is a vital resource for an organization and it needs to be managed with care. Information technology has largely contributed to the effective use of information and extends to all parts to the educational enterprise covering the aspects such as security needs, both for the protection of facilities and equipment's and for the assurance of the safety of students and staff, the integration of technology into areas such as facility design and professional development and training.

There is a range of potential uses of information technology in schools from simple interactive software for classroom teaching, distance learning to automation of school administrators; activities such as recording and reporting assessment data [1][2]. Therefore, the schools must develop a management information system for their efficient functioning. The school management system (SMS) provides information to manage the institution efficiently and effectively. They provide an objective system for recording and aggregating the information supporting the strategic development. Since MIS supplies the decision-makers with facts, it supports and enhances the overall decision making process of the school.

I. School Management Information System

Telem defined the school management information system as “a system designed to match the structure, management task, instructional processes and special needs of the school”[3]. Such systems also increase the effectiveness and efficiency by saving time and facilitating strategic development of alternative solutions for sophisticated problems.

School management information systems have worked toward the areas of leadership, decision making, workload, human resource management, communication, sustainability, responsibility and planning. In other words, it is helpful in managing overall functioning of the schools i.e. making programs way more effective, making the teaching process and the learning environment professional, enabling teachers to exchange their experiences in a more systematic and understandable way, working in teams, determining the needs of the students, supporting the school managers and other staff in doing their duties, developing their performance, effectiveness and efficiencies.

Research has been conducted in various countries which points towards increase in organizational and managerial effectiveness in schools after a MIS is established. In his study where Gurr examined the effects of information systems on managers of local schools, he determined that information systems have largely impacted on the role of school managers [4][5]. Studies have shown that a manager who does not use the information systems precisely is not able to achieve his duties sufficiently anymore.

It has been found that although there are many researches on the role and necessity of information technologies in education, many of these are about the educational functions and role of information systems and just a few of them are about school management [6]. Thus, the arena of school management systems needs to be explored in depth.

II. Role of School Management System

Management information systems play three vital roles in educational institutions. They support operations of the institutions, guide managerial decision-making and provide strategic and competitive advantage to the institution. These systems retrieve information (about internal operations) from databases that have been updated. The managers specify the kind of information they need and it is sent to them in the form of reports.

School management information system is essentially a computer program on which all important information can be stored and it saves time while doing many repetitive tasks. Schools can use MIS to measure performance, manage resources and help the employees to comply with the regulatory requirements. Certain areas of school which could be successfully included in an SMS are shown in the Fig 1 given below:

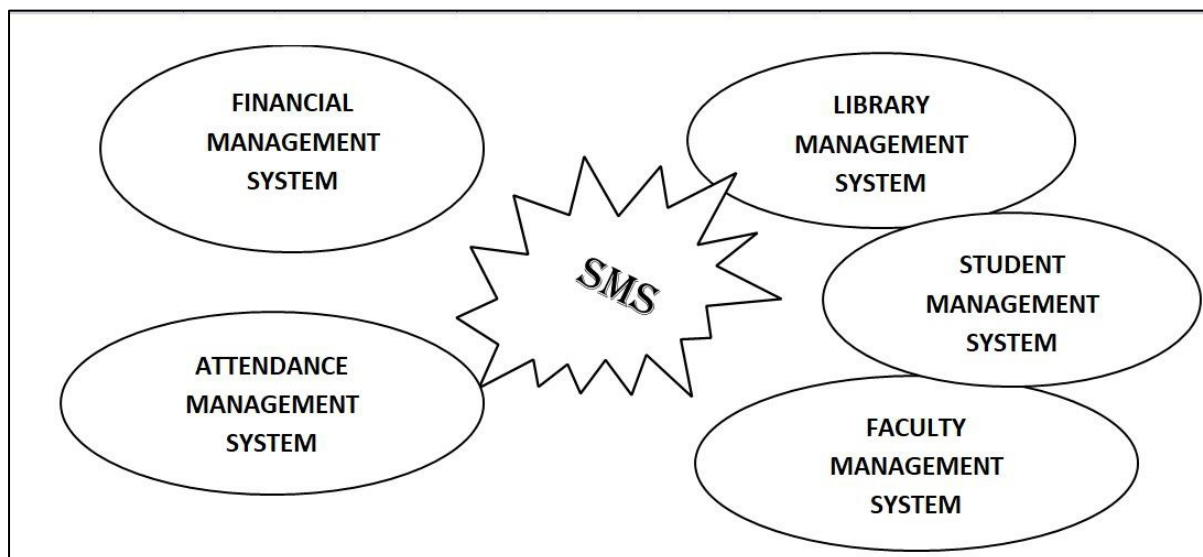

Fig 1. Block Diagram of SMS

Student Management System (SMS)

Student Management System is the main database module, holding a wide range of personal information about each pupil. The most important aspect of it is the way it needs to integrate with other modules throughout the SMS system. A properly designed SMS gets rid of repetitive entry of personal data to produce outputs including attendance reports, profiling and library readership lists. A student record can begin before they are admitted by entering basic details. As a student enters into the school, information needs to be added continually to the record or updated; managers editing routines provide for quick global editing of data. The multiple levels of access and password protection ensures that sensitive information is available to the operators who need it. The student management system contains the personal information, for example, name, address, parents contacts, date of birth, sex etc. At the time of insertion of a student record a unique student ID is generated and password is prepared taking the student's unique ID and the last four digits of its phone number. This provides a unique set of access key IDs with a password to each student.

Attendance Management System (AMS)

The attendance management system (AMS) is necessary for registration and truancy monitoring. The student's attendance and absence should be recorded and linked to the attendance standards. AMS is used to collect and analyse attendance information in order to check whether the individual students' attendance in the classes can satisfy the regulations of the educational offices and produce reports that simplify the monitoring of group and individual attendance patterns. As the attendance data are to be entered very frequently and on a continuous basis, a number of data entry options can be considered. The attendance management system records absentees for a specific session or for a given period and attendance record for examination eligibility and scholarships. It also provides information regarding issues of absence notification letters for the parents.

Faculty management system (FMS)

In the 21st century the schools have realized that their staff represents their greatest asset; hence the management of the human resources assume great significance for school effectiveness. This module includes the teaching faculty and records all their information including the education qualifications, contact, date of birth etc. This module generates and assigns an ID when we start to insert a faculty record. The information from the faculty management system module integrates seamlessly with modules from the curriculum areas to produce assignments, news, attendance records etc. Teachers can also give assignments to students mentioning the last date of submission. Any news regarding exams or events can be given through publishing news.

Financial Management System (FIMS)

Financial Management System is a comprehensive accounts management system which helps to cope easily with the requirements of managing an educational budget. It keeps the records of fees paid by the student, the due amount and the amount received till now. 'Clear all dues' option has been provided to cancel out all the dues for a given student. This module also holds the records of teacher's salary. The Financial Management System is helpful in creating order details and pupil invoices can be directly created from the information held within the software saving massive amounts of duplication of effort.

Library Management System (LMS)

The modern schools are defining their destinies and in particular they are taking charge of their own premises. Library Management is the distinctive feature of this module that not only provides us with asset management but also helps us maintain the track records of all the library stock. We can add or delete the book, including the book category as fiction, literature, sci-fi etc. We can also manage the books issued and the date of return etc.

I. Conclusion

The pace of change brought by new technologies have a significant effect on the way people live and work throughout the world. New emerging technologies challenge the traditional processes of teaching and learning, and the way education is managed in a generation today. Information technology is having a major impact across all curricular areas of the school. The school management systems are essential for effective management of educational institutions. School Management System is essentially a computer program on which all important information can be stored. It saves time while doing many repetitive tasks. A school requires an information system for managing several tasks such as student's data, attendance, assignment, news, financing and library books management. At the click of a button, a teacher will be able to have prints of class lists and records and communicate the data to other teachers. The collection and analysis of data can also be done easily and quickly. A well-designed and well-maintained School Management Software allows the information to be entered once and used many times, which can save time for many routine tasks and speed up the transfer of information when children move between schools, improving the quality of information made available to parents and other interested parties. An effective SMS should be accessible to both staff and parents.

References

- [1] Anderson, R.E. & Dexter, S. (2005) School technology leadership: an empirical investigation of prevalence and effect. *Educational Administration Quarterly*, 41(1), 49-82.
- [2] Gehlawat, M. (2012). *IT in Education*. New Delhi: Pearson Education India.
- [3] Telem, M. (1999). A case of the impact of school administration computerization on the department head's role. *Journal of Research on Computing in Education*, 31(4), 385-401.
- [4] Dr. R. Nageshwar Rao, *Core Java, An Integrated Approach*
- [5] <https://www.geeksforgeeks.org/Managementsystem>
- [6] <https://www.quora.com/schoolsystem>

Blood Donate Mobile Application

Kriti Malpani and Manisha Shresth

*Students, BCA III, Department of Computer Science
St. Xavier's College, Jaipur*

Abstract

There is an expectation that the blood will always be there when it is really needed. Blood donor volunteers constitute the main supply source in an effective blood supply chain management. They feed blood stocks through their donation. In an emergency situation, if the stocks are insufficient, the only source of blood supply will be the people who come to the health centre and donate the blood on a voluntary basis. It is certain that time is a very important component in such a situation. For this reason, the health care centre should call the nearest available donor in order to ensure to get the service as quickly as possible. A smart phone application is developed to facilitate the identification of the nearest available blood donor volunteer and the communication with him/her in the emergency situations where the blood can't be supplied through the blood banks' stocks. In this paper this application has been presented.

Keywords: *Blood supply management, Blood transfusion, donors, android application, google maps*

I. Introduction

Despite all the advances in medicine and technology, an alternative medical way to substitute blood, blood components or blood-derived products have not been found yet. Blood can only be supplied by living donors. Blood transfusion has been responsible for saving millions of lives each year around the world. Yet the quantity and quality of blood pool available for transfusion is still a major concern across the globe, especially in the developing countries.

According to the survey conducted there are three types of blood donors: a) Voluntary donors, b) replacement donors, and c) professional donors. Most donations are as a result of replacement donations provided by the relatives of patients. In case of operation or treatment, health care centre employees asked to patient's relatives to donate blood even if they don't have the same blood group. Professional donors are those who donate blood in exchange for money. Unfortunately, these two types of blood donors don't help maintaining a reliable stock of blood. Moreover, they do not provide rare blood groups. These points indicate the need and importance of voluntary blood donations. Voluntary donors are non-remunerated donors and donate blood voluntarily without any inducements such as money or any other substitute of money. Such donations are providing adequate round the clock availability during emergency situations and they are the source of safe blood also. The sustainability of a safe and adequate blood supply is still provided by volunteer blood donors.

Almost all over the world, blood recruitment services are conducted in a systematic way. There are many blood centres in India. They are mostly in big cities. there isn't much coordination between all these institutions with small cities and the blood recruitment management face problems due to shortage and unavailability., In an emergency situation or a chronic disease case, when the blood stocks are insufficient to fulfil the requirement, the blood is supplied via public announcement through the traditional or social media, which may not always result in a successful way [1]. In order to maintain continuous blood recruitment, blood banks should implement different campaigns for encouraging people to become a registered volunteer donor [2]. Also, they have to facilitate the blood donation process with

help of new technology in order to increase the volunteer donors' willingness and accessibility. Market research experts define the different generations found in the blood donor population. The common characteristic of a large part of this population is to be digital natives whose smartphones are ubiquitous.

Blood donation app is an integrated information system whose aim is to manage the blood donation and blood supply chain. The proposed system is used by the patients and/or relatives of the patients to notify their blood requirements and by the living donors to be aware of these requirements.

When the blood request is defined into the system, the system checks the stock of the blood banks in the neighbourhood. In this way, the system can declare quickly whether the blood needed can be supplied or not.

If the blood needed cannot be supplied from the neighbourhood blood banks, the system sends a request to living donors of the same region, via the mobile application installed in donors' smartphones and interprets the response coming from the donors.

If there is any affirmative answer from the living donors, the system informs the related health care provider. Blood donation app seeks to provide services to different kinds of users such as healthcare institutions, blood banks, volunteer donors, patients or their relatives.

Therefore, its infrastructure is designed to be as flexible as possible, in order to ensure data exchange easily between the organizations.

Blood donation app helps in finding local blood drives and donation centres quickly and easily, it is convenient, easy appointment scheduling and rescheduling, keep record of results from your mini physical, keep track of total blood donation.

II. Methodology

(a) Operating System

We chose to use the Android software stack produced by Google. Android is an open source framework designed for mobile devices that packages an operating system, middleware, and key applications [1]. The Android SDK provides libraries needed to interface with the hardware and make/deploy an Android application [1]. Applications are written in Java. Android uses a SQLite database to store persistent data. Unlike dedicated systems, our software is intended to integrate with the phone's existing applications. Our application must share resources with the other application. To make for a pleasant integration, the application runs as inconspicuously as possible while using limited resources.

(b) General description

The application is developed for smart phones using the Android operating system. The main duty of the application is to notify regularly the donor's location to the Blood donation app. The process of being a registered donor of a Blood donation app consists of the following tasks: Volunteer to be registered as a donor into the system. This app is a smart information system, and all users' interventions are minimized. The username and password to the volunteer is given as soon he/she downloads the application into his/her smartphones and register.

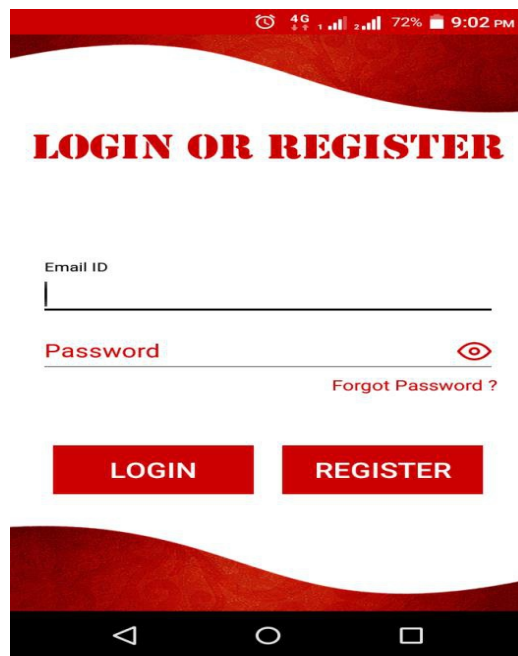

Fig 1. Login

Fig. 1 and fig.2 illustrates the login screen of the Android application. Login Screen of Mobile Application Once donor connects to the system, the application downloaded into his/her smart phone starts to send his/her location information to the main system.

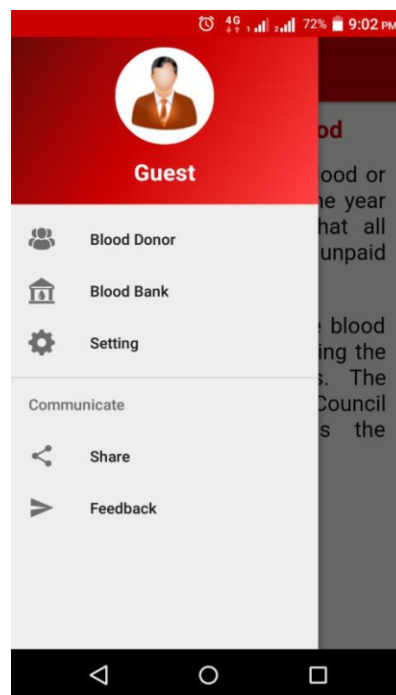

Fig 2. Guest Login

The user can even login as a guest and can access all the resources provided.

When a request is defined, the system allows applications to run on top of it, while there is minimization of the memory consumption and user interaction. The application is developed for smart phones using the Android operating system. The main duty of the application is to notify regularly the donor's location in the app. The process of being a registered donor consists of following tasks: Volunteer uses app to be registered as donor into the system. It is a smart information system, and all users' interventions are minimized.

The app starts with a splash screen and pops up to a display stating random articles as shown in fig 3 and 4.



Fig 3. Blood Donate

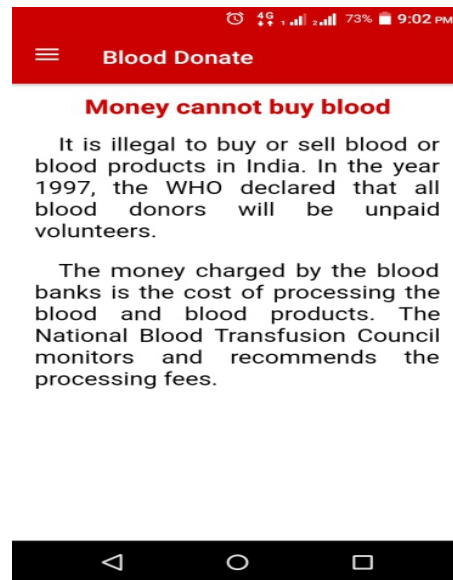

Fig4. Disclaimer

The user can register himself by entering all the details asked (Fig 5) regarding name, blood group etc .After registration the username and password is provided to the user.



Fig 5 Registration

Fig 1 illustrates the login screen of the Android application. Once a donor connects to the system, the application downloaded into his/her smart phone starts to send his/her location information to the main system. Two of the common problems in mobile phones' applications are the optimization of battery usage and mobile data exchange. In order to control these two usages, the update frequency of volunteer donor's location information is left under the control of the user. As shown in Fig 6, users can select their gender while creating their profile, and as shown in Fig 7, users can enter their DATE OF BIRTH.

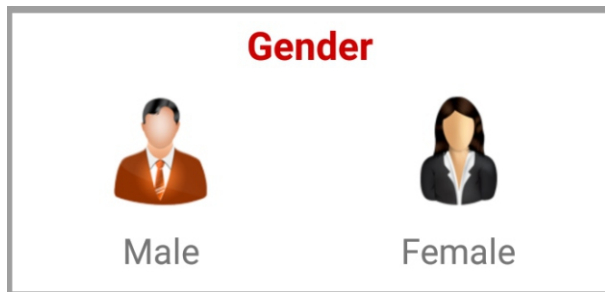

Fig 6. Gender

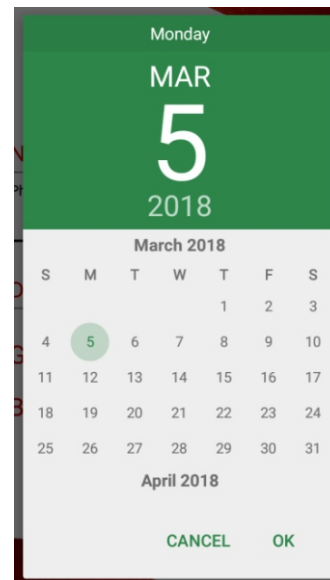

Fig 7. Calendar

For better experience, while registering, users have to enter their Blood Group (Fig 8) so that people in need can contact them according to their preferable blood groups.

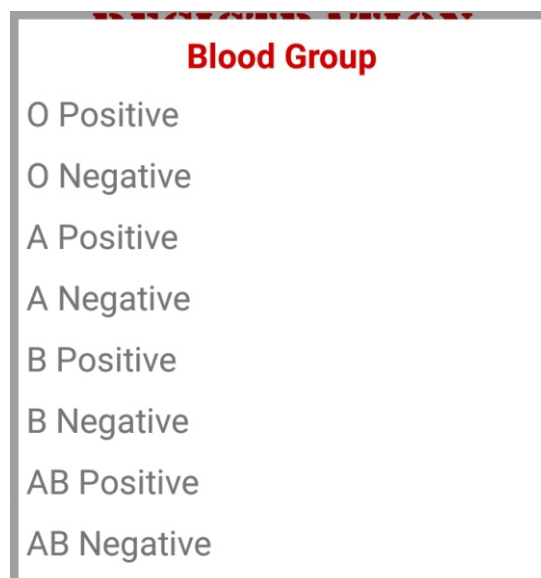

Fig 8. Blood Group

After registration/login, the user profile will display as shown in Fig 9 and Fig 10. If user wants they can edit their profiles using the edit profile screen (Fig 11)

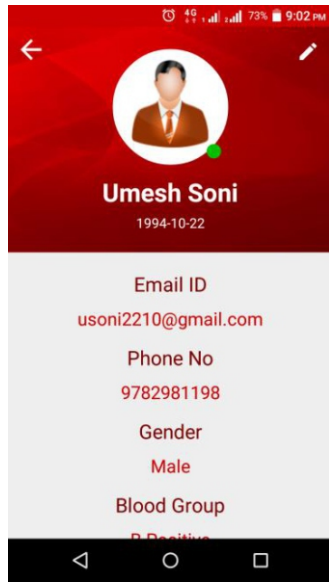

Fig 9. User profile

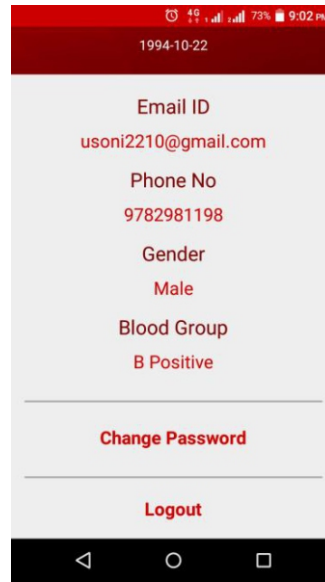

Fig 10. Details

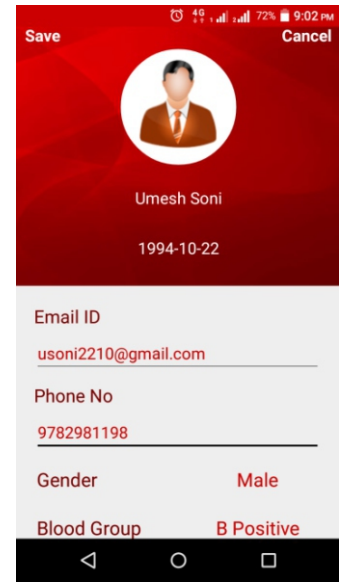

Fig 11 Edit

In case, a user forgets their password or wants to change it they can do it using the Change Password option (Fig 12) or Forgot Password option (Fig 13) they will receive an OTP using which they can login in case they forget their password? (Fig 14)

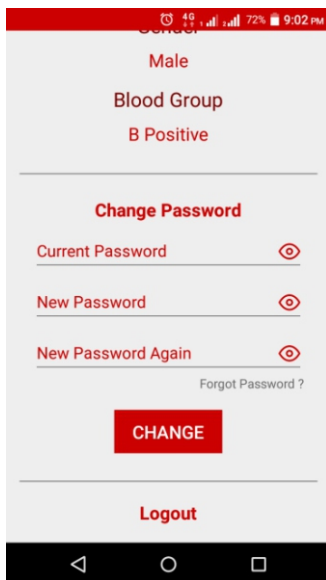

Fig. 12 Password Reset Process

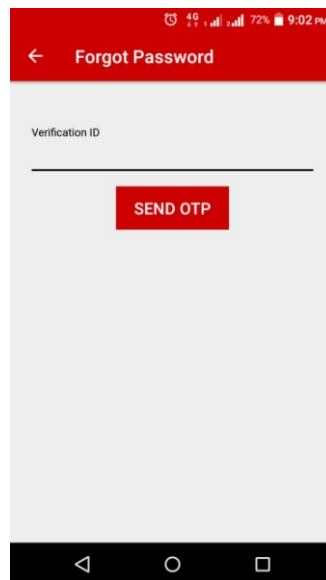

Fig. 13 Password Reset Process

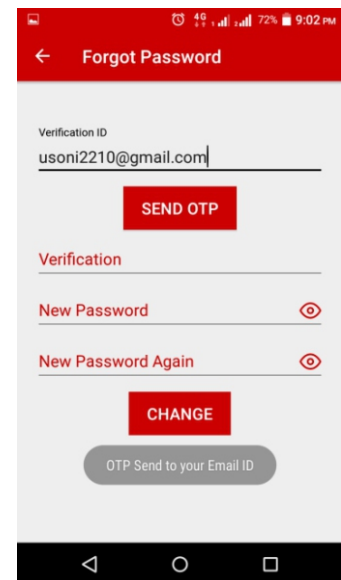

Fig. 14 Password Reset Process

© Optimization

Just a single search allows user to reach the maximum number of blood donors in minimum possible time and that too within just 5 km from where the blood is required. (Fig 15) (Fig 16)

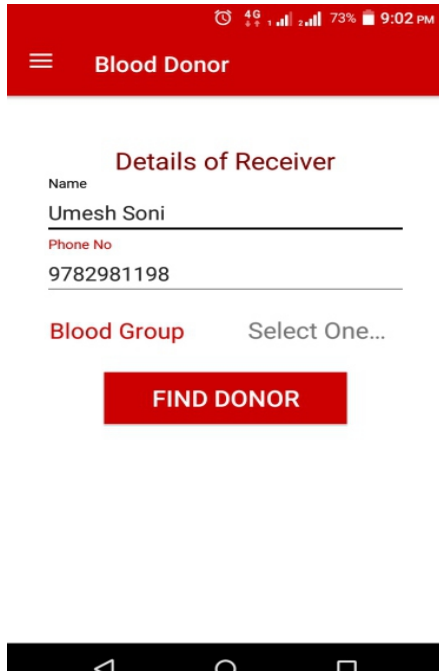

Fig 15 Process Optimization

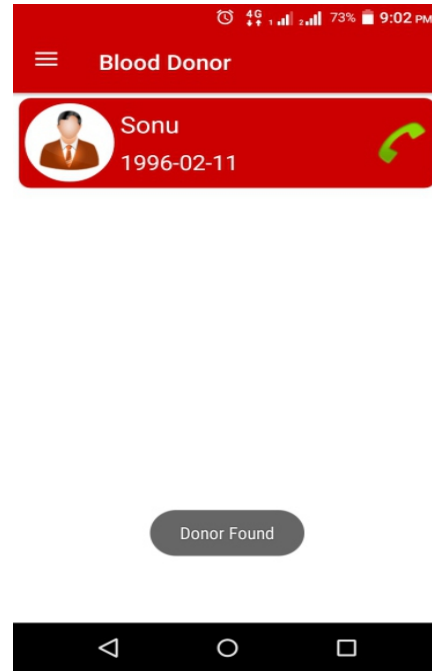

Fig 16 Process Optimization

Users can use a toggle button as shown in Fig 17 to on/off the Donating Blood setting. When this option is on, the user will be shown in search lists; it indicates that they are ready to donate

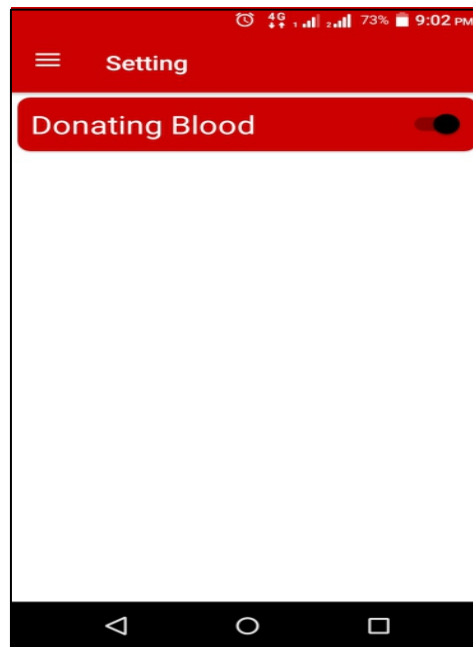

Fig. 17 Settings

(d) This app can easily find all registered blood banks and their contacts, with location that can be accessed through Google Maps. All blood banks located within a 15 km radius as shown in Fig 18.



Fig 18. Contact Details

User can also share Blood Donate App to various other platforms (Fig 19) (Fig 20)

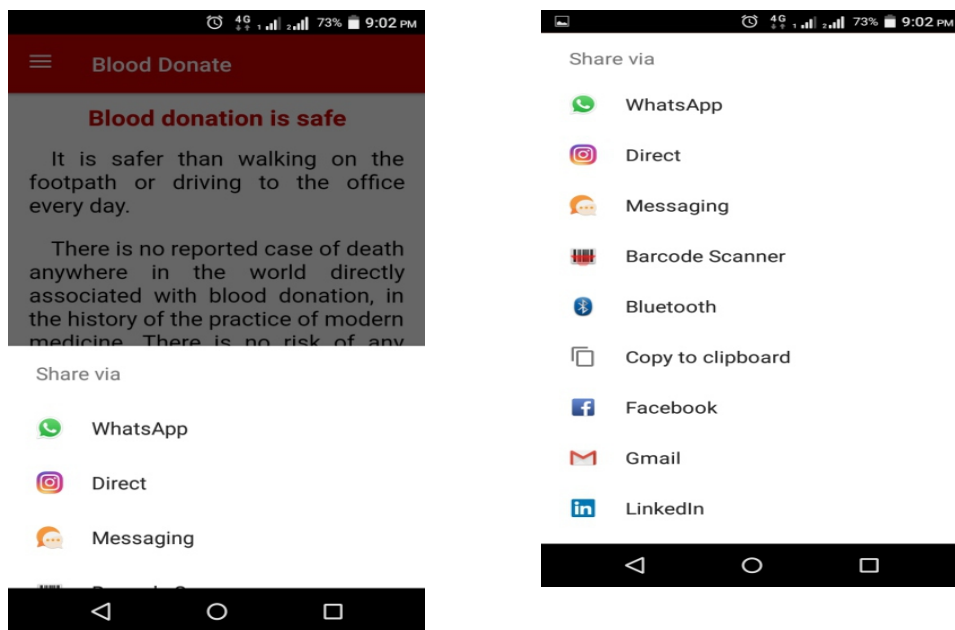

Fig 19,20 Share App

V. Conclusion

In this study, a smart phone's application for the volunteer blood donor to increase the willingness and accessibility with the purpose of providing a continuous blood supply we presented. This application helps health care centers to provide the blood as quickly as possible when their stocks are insufficient. The application periodically sends actual location information of available donors to the main system and the blood requests to the donors. In this way, it provides an uninterrupted communication between the health care centers and

volunteer donors. The distance of the volunteer donors to the healthcare centre is an important criterion in the determination of the donors. Therefore, an optimization is also realized in this process. In the initial system, the distance calculation. This optimization makes the system more realistic. The second improvement is performed on the system's infrastructure. Especially, by taking into consideration the rapid development of mobile device technology which uses Android operating systems. In further studies, we aim the add evaluation of traffic density between living donors' locations and healthcare centres to the living donor selection criteria.

Acknowledgment

This research is supported by my brother, without his guidance this would be hard to achieve.

References

- [1] Williamson, L. M., & Devine, D. V. (2013). Challenges in the management of the blood supply. *The Lancet*, 381(9880), 1866-1875.
- [2] Gillespie, T. W., & Hillier, C. D. (2002). Blood donors and factors impacting the blood donation decision. *Transfusion Medicine Reviews*, 16(2), 115-130.

Payroll Management System

Varun Nandwani, Jagpreet Muchhal, Pushpendra Achora

*Students, BCA III, Department of Computer Science
St. Xavier's College, Jaipur*

Abstract

Payroll management system is a software that allows the businesses organisations/institutes to input, process, update, store its employees' attendance and payment data. It is an organised system that make it convenient and easy for the managements to maintain the payroll system of the organisation. It is suitable for all kind of organisations – small scale, medium scale, large scale, profit making or non-profit making organisations. Since, the process of maintaining the employees has become complex with various aspects added to the businesses. Our Payroll System aims to solve the issue of improper management of the employees. Through the use of advance methods and working, it is helpful in reducing the redundancy of the data in the organisation. It uses up to date technology to cope up the challenges of the corporate world in maintaining their employees' payment details and history.

Keywords: *Payroll system, cohesive, employee, salary management, database.*

I. Introduction

As the technology has revolutionized every industry have massively improved their efficiency but improve the management of the systems in every way. The payroll management system is core system for any organization. Our system is developed for the leading organisations that wants their payroll systems to automated, fast, secure and easy to handle. Our Payroll System can handle enormous amount of data as it uses industry leading database management technology – MySQL. It is considered to be an industry leader for the most secure, fast, reliable working database system.

This payroll management system has improvised all the basic exercise to manage the salary of the employees. This automated the whole of salary management which was previously done by manually. It will be a more efficient system to rely on for the industry as it reduces the time of the operations which will basically take more time manually. The main modules of the system: Administration, Employee, Departments, Salary

Now to understand the working of the system properly we are required to understand what does each module does that way integration of the modules will be easy to understand the working of the whole system. It is a good practice to make the system's module loosely coupled and more cohesive that is because then it makes easy for the modification and changes at any single or multiple modules and not the whole system. Making the database centralized in the company so that each authorized device can access the required information. It will also enable the industry save the previous record easily if required in future.

II. Methods and Methodology

The system has been developed with an aim to perform in the real-world situations where organisations have multiple locations of work. In today's world, number of employees in an organisation are scattered over various locations. Hence, this has be given the most

importance to make the application working across all locations with data being centralised and secured. This issue is solved by implementing the Server-Client Model which makes software use being scattered but yet data under control by making databases central. A server is setup that accepts the queries from the client computers and provides them with required output. This model can be used by a small organisation by making the server and client on the same device which also make it to be a good standalone software. Also, can be expanded to multiple servers and clients, as the need may be. This is made possible by various tools that helped us to develop this effective yet light-weight application with minimum efforts possible.

Software Requirements

- Java (GUI, JDK 1.8) for front-end development.
- MySQL 8.0 for back-end database.
- JDBC (Java Database Connectivity) for the connections between the two.
- Eclipse and NetBeans IDE.
- Maven (Project Management Tool)
- MS Office

Key Modules of the system are:

(a) Login

Security is the most demanding feature in the current scenario with lots of the unwanted access to system. Authentication is one of the most vital feature and first step to prevent unauthorised access to data. Our software implements this by using username-password combination that is securely stored in the database.

In the factory state, software has a default password that can be changed accordingly after logging-in. It is the first frame/window that user encounters when they open it. This frame adds security to the software.

(b) Home

A home frame is the main frame of the system that contains all the options and features for the user to choose. It contains all the buttons and options that user can direct to. You can imagine it as an index of the book that shows the content of the book but in this case, it is the software features it is displaying. Our system's home frame is kept simple and user-friendly for everyone to use and take advantage of this technology. Provided options are as following

Create/Modify Button

This option allows the user to create, update, remove employees, departments or shifts. This also provide an option to change login credentials for the user. Options available in the frame are:

- Add Employee: Accept details for the employee such as *employee id, Name, contact no, address, department, working shift, pay-per-hour, leaves allowed.*
- Remove Employee: Provides option to search details using *employee id* then the user can delete the employee after verifying the details.
- Update Employee: Provides option to search details using *employee id* then the user can update the required fields as per needs.

- Department: Lets you create departments as per organisation's requirements. Also, provides and option to alter the department details.
- Shift: Lets you create working shifts as per organisation's requirements. Also, provides and option to alter the shifts.
- User: Make changes to the login credential.

Report Mode – Formatted and systematically arranged output occupied after inputting and processing the data is called a report. Our payroll system provides reports in multiple formats – Master Attendance, employee wise attendance, amount payable report. You can easily get the report by selecting the time period and employee id. Reports are in tabular form and provides date, entry time and exit time of the employee. Generation of reports is real time and reported generated by our system is always updated to latest changes. These reports then can be used directed or by exported into various file formats suiting the needs of the organisation. Options available in the report frame are:

- Master Attendance: Provides attendance of all the employees for period of time as entered by the user. Useful for overall analysis for attendance of employees.
- Employee Wise Attendance - Provides attendance of a single employee for period of time as entered by the user. Report generated are based on *employee id*. Useful when individual performances need to be analysed.
- Amount Payable: The most important report is the payable report as it show the details for the amount to be paid to the employees.

Entry Mode – To generate reports or to store data, first the data has to be entered and out payroll system provides two easy to use entry patterns based on the needs of the user. Sometimes, the user needs to enter attendance for a date for all the employees, for that we have Date wise entry mode. Contrarily, user also wants to enter attendance for a particular employee, for that we have Employee wise entry mode. We have made provisions for both modes. Entry Mode frame has two options, namely:

- Date Wise Entry: User selects a date to enter attendance data for all the employees for a particular date. A table populated with the names and other required columns, user can them enter the entry and exit time in the blank field in the table. Useful for daily attendance entry.
- Employee Wise Entry: Provides a field to search for an employee and then attendance data can be entered for the particular employees for multiple dates. Useful when individual employee's attendance to be entered.

III. Results and Discussion

This project was developed for educational purposes, so, it is first tested in our educational system to find bugs and errors that could not be found at once while developing. The efforts are made to cover every possible real-life problem that this project could face. We created real-life working situations for the software to handle. Every project has shortcomings before it is corrected and so this too had many errors which were fixed and the system was made functional, as it is intended to. Many more bugs are expected before this project could be used in any organisation in real life. Most importantly, the software was able to fulfil its purpose of development and the results were impressive. This project is made universal in its structure and could be changed as per client's needs.

IV. Limitations and Scope

This software is not optimised for all the devices and operation systems. It is developed using Java which is a cross platform programming language. So, we would be able to optimise our software once we get to test it on many platforms and systems.

Doesn't suit every organisation. Since, every organisation has its own working constraints, we would tailor every part of the software that would make our software suitable for the them. A lot of competition is there. Our software base is strengthen by providing best services at most reasonable prices. Many competitors are providing software at costs that not all can bear.

Server-Client Model is expensive to setup for many businesses. To overcome this, we are planning to provide our servers to small scale businesses at very nominal costs reducing their costs at beginning and also in long run.

More Secure. Although, one of the most secure databases – MySQL I used along with very secure language Java and JDBC connectors, and deployment using an encryption mechanism would make it more secure and less prone to attacks. At last, all possible efforts are made constantly to find problems and their solutions to make this system better and reliable in the coming future.

V. Conclusion

We have mentioned every possible detail on our project but may have missed something. This project was inspired by the problems faced while handling human resource and their attendance by manual entries and calculations. There are many discrepancies which arises due to mishandling and negligence of employers while making attendance sheets and payroll reports. These problems are solved by implementing technology to the organisation's workings. We have also found the business work effectively and more organised by using these systems. As employees increase, complexity of handling their data also increases but this software is designed to handle these growing challenges making it ideal for every organisation. Its cost-effective option – cloud platform also make is attractive to small business that can afford their own infrastructure. We aim to make this project more practical and workable with better outputs to organisations. We would like to conclude that this would become better once it goes in hands of any corporate or non-profit making organisation.

VI. Acknowledgement

The success and final outcome of this project required a lot of guidance and assistance from many people and I am extremely privileged to have got this all along the completion of my project. All that I have done is only due to such supervision and assistance and I would not forget to thank them. I respect and thank the department faculties, for providing me an opportunity to do the project work in St. Xavier's College Jaipur and giving us all support and guidance, which made us complete the project duly.

References

- [1] <https://smallbusiness.chron.com/meaning-payroll-system-61432.html>
- [2] <https://stackoverflow.com/>
- [3] <https://www.javatpoint.com/>
- [4] <https://www.geeksforgeeks.org/java>
- [5] <https://www.mysql.com/>
- [6] <https://www.tutorialspoint.com/mysql/index.htm>
- [7] <https://www.mysqltutorial.org/what-is-mysql/>

Jewellery Design and Management System

Komal Khatri and Ashpreet Singh

*Students, BCA III, Department of Computer Science
St. Xavier's College, Jaipur*

Abstract

Mobiles have gained unprecedented importance in our lives, today. People around the world choose mobile devices as their preferred medium to connect with other people, gather information or even do business. As a result, many businesses are actively devising new mobile marketing strategies to reach out to their audience. Online selling is a next generation trend of dealing in products and services. This strategy is being practised by most of the traders and businessmen across the globe through which they communicate or engage with their potential customers in an interactive and relevant manner. In this context, we have developed a website with domain name "jaipursilverjeweller.org", to explain more about jewellery.

Keywords: *Jewellery Design, E-commerce, gemstones.*

I. Introduction

In the present world, mobile marketing is a common technique that almost every company, irrespective of the business it is into, is pursuing some kind of mobile marketing campaign. Whether it's an E-Commerce giant such as Amazon or a manufacturing juggernaut such as General motors, everyone is following a "Mobile first" approach when it comes to creating a marketing strategy for their businesses. Introduction of our "jaipursilverjewellery.org" is a website for Jaipur Silver Jewellery which focuses equally on quality and quantity. It is maintained for the production of jewellery and represents the jewellery store in Jaipur[1][2][3].

II. Methodology

The methodology used in our paper is that the processes of designing, coding, and testing have been performed for this website to be attractive and appropriate.

When any user visits the system, he/she may click on any link and the desired page will open. For example, if the person wants to know about the materials used, he can click on the link 'About Jewellery' and all information regarding the jewellery products displayed on the website. Users can place the order and make online payment through the secure gateway or other options provided by us. Users can also opt for cash on delivery in case he/she is not comfortable with online transactions.

Software Requirements

The system is designed using the most common language i.e. HTML. For layout appearance CSS has been used. PHP has been used for sever side programming. Since PHP requires specific software for support, XAMPP has been made use for running it. Photos are edited using the most adequate application Photoshop. The coding was saved in notepad++.

System's Key Modules

Quality- Through this section, one can ensure the purity and impurity of the material used in the Jewellery.

Customer service- On the website there is a page where you can ask your questions or queries regarding our products. Our contact has also been written there like address, phone number, e-mail where you can send us your queries.

Exhibition and shows - When user opens this link, all the places where the exhibitions are held are presented beautifully along with the photographs. The shows sponsored and hosted are also made available to the users.

Products- A list of the product lines is presented.

- Gemstone Silver Bracelets - Images of Gemstone silver bracelets are demonstrated. This is our exclusive collection offered directly from our wide network of handicraft artisans.
- Gemstone Silver Earrings - Images of Gemstone silver earrings are demonstrated. This is our exclusive collection offered directly from our wide network of handicraft artisans.
- Gemstone Silver Necklaces - Images of Gemstone silver necklaces are demonstrated. This is our exclusive collection offered directly from our wide network of handicraft artisans.
- Gemstone Silver Pendants - Images of Gemstone silver pendants are demonstrated. This is our exclusive collection offered directly from our wide network of handicraft artisans.
- Gemstone Silver Rings - Images of Gemstone silver rings are demonstrated. This is our exclusive collection offered directly from our wide network of handicraft artisans.

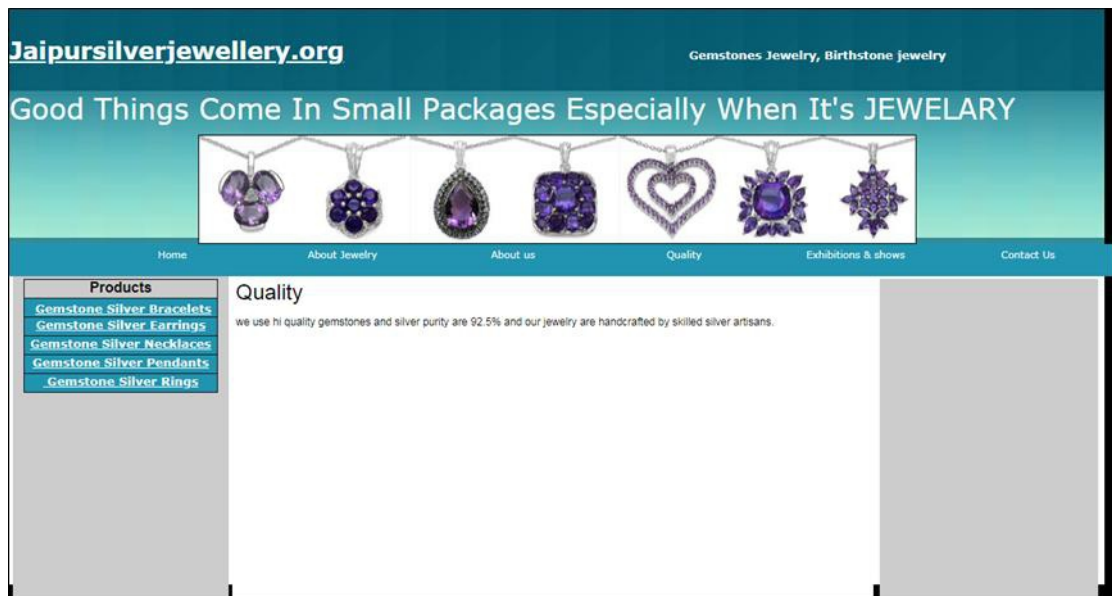

Fig. 1 Quality Module

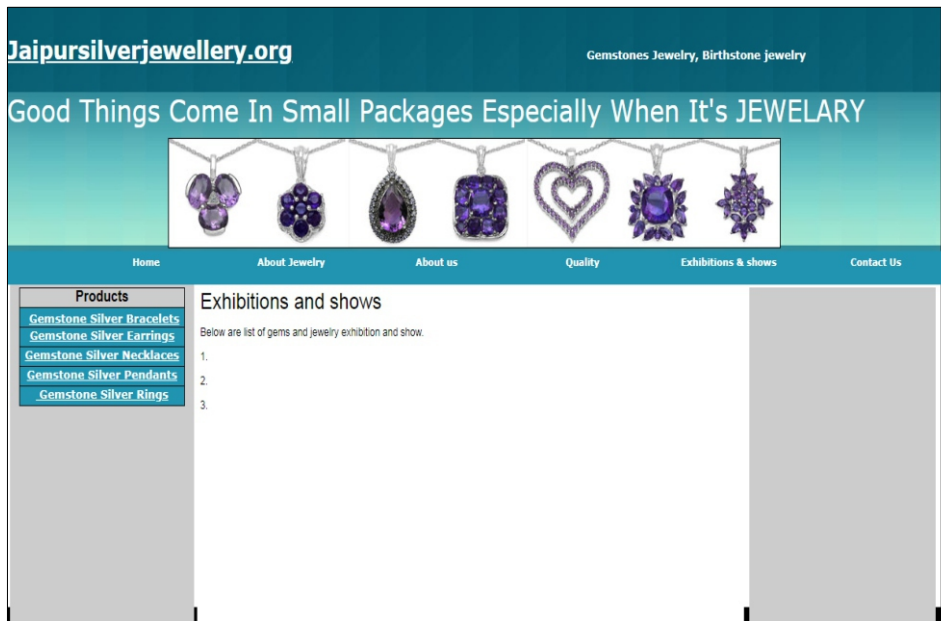

Fig. 2 Exhibition Details Module

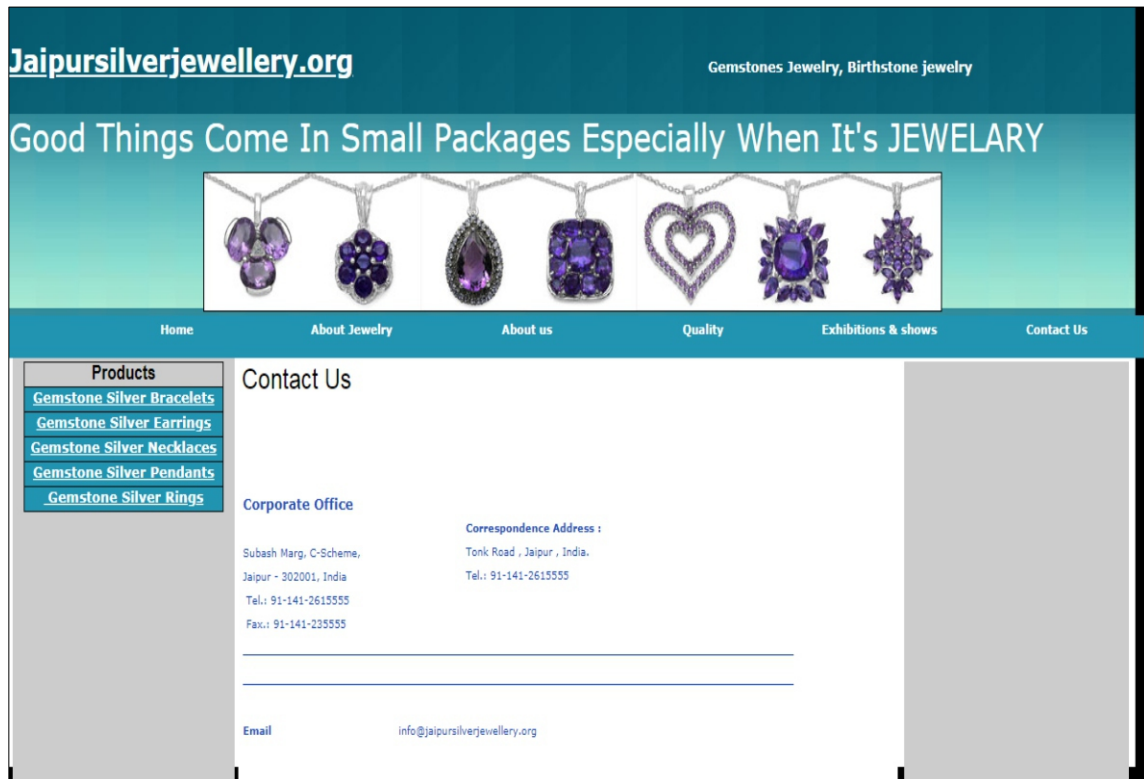

Fig 3 Contact Us Module

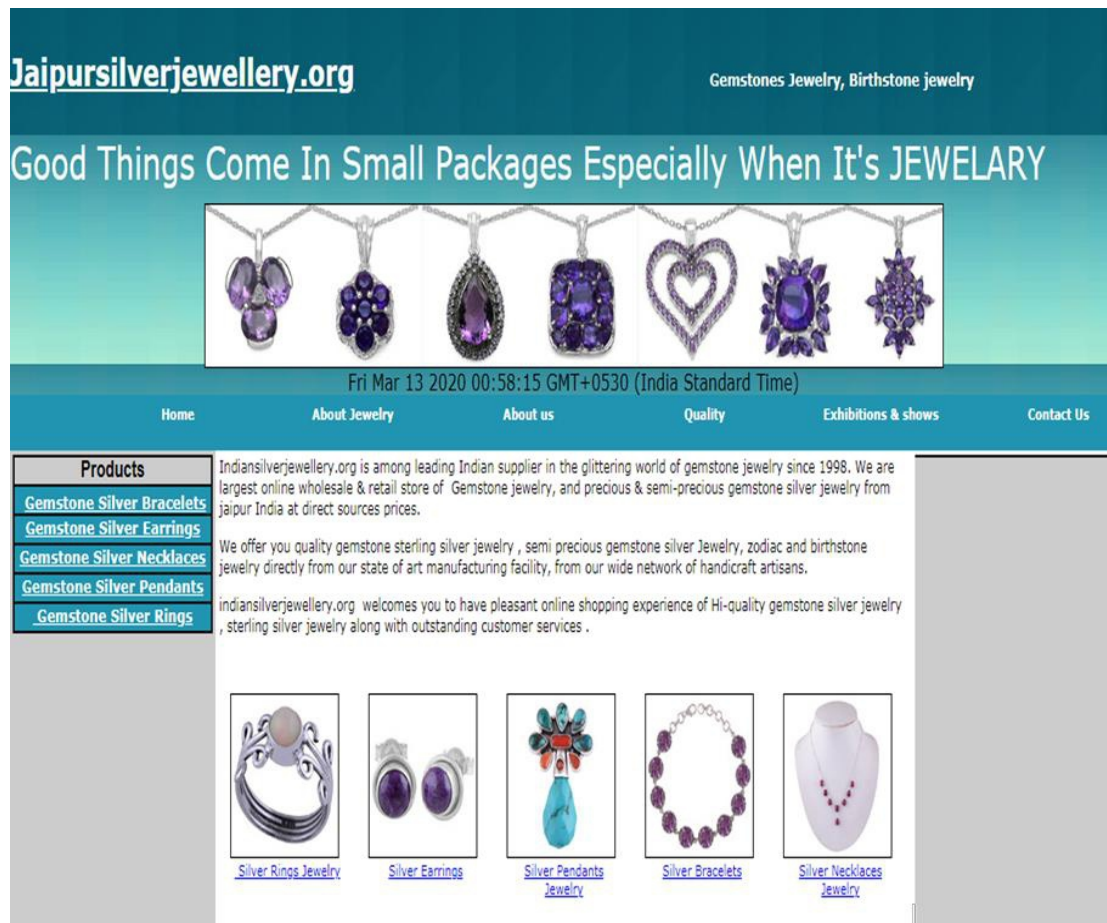

Fig. 4 Products Module

III. Advantages of the System

- End-to-end solutions.
 - a. Online Marketing
 - i. Banner Ads
 - ii. Affiliates
 - iii. Email campaigns
 - iv. Social Media Marketing
 - v. Digital marketing
 - b. Portal Management
 - c. Web hosting
 - d. Software updates
- Locality and availability.
- Our software
 - a. Advance B2B and B2C solution
 - b. Regular software updates
 - c. Tried and testing application

Benefits of online selling

Electronic commerce can offer both short-term and long-term benefits to the companies. Not only can it open new markets, enabling you to reach new customers, but it can also make it easier and faster for you to do business with your existing customer base. Moving business

practices such as ordering, invoicing and customer support to a network-based system can also reduce the paperwork involved in business-to-business transactions. When more of the information is digital, one can better focus on meeting your customer's needs. Tracking customer satisfaction, requesting more customer feedback, and presenting custom solutions for the clients are just some of the opportunities that can stem from online selling.

IV. Conclusion

Businesses are aware that the use of and influence of mobile phones today have gone up since the days of the simple text and voice messages. The companies create short, but interactive messages specifically to deliver on mobile devices. People order meals from a restaurant, buy and read a book/magazine/news, and find a childhood friend all with a single tap on their smartphones. Keeping this fact in mind, in this research we make a conclusion that, as the technology emerges, it is possible to upgrade the system and can be adopted to the desired environment.

References

- [1] <https://www.google.com/websitedesign>
- [2] www.w3schools.com/php
- [3] www.jaipursilverjewellery.org

Foody Funday: A Restaurant Management System

Abhinav Sharma, Chhavi Prakash Saxena, Kalika Bargota, Samerth Sharma

*Students, BCA III, Department of Computer Science
St. Xavier's College, Jaipur*

Abstract

In this era of modern technology where time is everything, we took our time to make this website intuitive for all the age groups, its for people to browse and book from home their desired table, the amazing view, choose menu of interest, and about everything which will make their night special if not perfect. This website makes it easy for celebrations, business meetings, birthdays, small get together to be organized without complicatein situation and running into a number of problems because of miscommunication, or in transparency. This paper is all about a system for restaurant work management. The system ensures a provision of smooth service of booking a table and look on the available food menu according to the customers for a great experience.

Keywords: Restaurant, Php, html, css, java.

I. Introduction

The traditional system of paper menu and ordering system is replaced by electronic medium with the help of digital gadgets. Due to a digitalised system, the risk of manual error is eliminated, thus eliminating the communication barrier. The Project entitled "Restaurant Website" is a web-based website developed in PHP, HTML, CSS and Java language. The website displays all the information that the customer desires about all the available tables and corresponding view. It maintains the details of customer payments, booking receipts, old or new customers, special dishes, booking form, reservation timings. As the continuously growing number of restaurants are being to provide another time, space, place, atmosphere or environment for every user. Booking tables on website make the restaurants and the customers experience a lot better as for the customer it can be easily done from the comfort of their homes and from a click of a few buttons and as for the restaurants it makes it easier to maintain and to reduce the communication gap.

This website product allows the owner, managerial staff, the customer and other interested parties to use the services at any time of the day. The internet works 24 hours a day, 7 days a week. So even if the restaurant isn't open website will be working! This study also allows people to potentially get in contact with the website, whether you're in front of a computer or not as it can be accessed from next to all devices including mobile phones, computers, etc.

This website makes it easier to find a table of your choice and helps chooses the time when the customer plans to arrive at. We understand the day-to-day hectic schedule and office life. So, website makes it very simple and attractive way to book reservation. Website has been made in languages like HTML, Java script, PHP, CSS languages. These are all for web programs, applications and projects. These all languages make it effortless to work and process on website. The functions on website are easy to understand.

In the modern age, people are using mobile phones more and more to browse the internet, find out about the new better options to get things done quickly and easily.

HTML is used to define the structure and semantics of our content; CSS is used to style it and lay it out which gives a good look on website. Also using Java script has made it easy to update information about customer or restaurant details. Common uses for Java Script include confirmation boxes, calls-to-action, and adding new identities to existing information. another is PHP which is used to access and modify data held on a database.

The project basically deals with the things which makes a lot of tasks effortless and less time consuming for everyone who is coming to our restaurant maybe it out the restaurants staff or the customer. Our Website provides full privacy security to our customers private information and we are as well aware of all kinds of attacks on institute which holds a lot of personal information. All and all we have taken all of this into consideration and have created an appealing, evident, and a very secure platform.

The main purpose of this system is to provide services to customers. It maintains the details of customer payments, booking receipts, addition of new customers, special dishes, booking form, reservation details and also updating, deletion for the same which can be very easily accessed by our customer on a click of a few buttons. The purpose of this website is to makes it easier to choose and select according to every customer demand and needs. This website allows the customer to choose and reserve table for breakfast, lunch, dinner, different events they wish to organize such as a birthday party or a get together by just virtually using the Internet and allowing customers to see the dishes available and specials of their desire from the restaurant. The goal of the website is to help save the time of our precious costumers as online booking does not require them to be physically present at the restaurant, thus they can book a table and choose a suitable view and even choose their meals from anywhere in the world. And the main goal of the website is to increase the sales as it will be more convenient for the customer. Keeping that in mind we have created a very user-friendly site. In edition it will improve interaction with existing and potential customers and will bring in a lot of new customers also becoming an authoritative resource which will establish trust among people.

II. System Methods

There are different methods of creating a web application. In this project " Foody Funday "four programming languages in an intertwined manner have been used, which reduces time to understand for the employees, makes employees all-rounder, helps in maintaining the standard and consistency of the operations even helps in increasing customer delight through consistent service. Here, HTML, CSS, JavaScript and PHP have been used. All of them has different techniques for different purposes. In today's generation these languages are important, appealing and easily workable.

HTML, or Hypertext Markup Language, is used to create web pages. HTML is the most search friendly programming language. We used HTML to format text as titles and headings, to arrange graphics on our web-page, to link different pages within a website, and to link different websites. HTML is a set of codes that a website author inserts into a plain text file to format the content. We inserted HTML tags, or commands, before and after words or phrases to indicate their format and location on the page. HTML tags were used to add tables, lists, images, music, and other elements to our web-page. Web documents contain three main sections: the head, title, and body. The head includes the web-page identifying information, including the websites title and important keywords. The viewer sees the websites title, but any other information is hidden.

All The major work of the website has been done in HTML. Our website is held altogether using HTML and all the other languages are used to supplement HTML and to make our website more dynamic. We have used Different types of HTML tags some of the are given below-

- `` tags for inserting Images.
- `` Anchor Tags for inserting links.
- `<div></div>` tags for making division.
- `` tags for bullets.
- `` tags for unordered list.
- `<form>` tags for creating Forms.
- `<p></p>` tags for creating paragraphs.

CSS is the language for describing the presentation of Web pages, including colors, layout, and fonts. It allows to adjust the presentation to different types of devices, such as large screens, small screens, or printers. From the accessibility point of view, applications of CSS provide much better solutions that allow us to update the users interface to suit the business requirements. Also based on the current standard, to develop any web-based application or any online community, the application in CSS can be implemented in different ways. It is more compatible and the website can be maintained effortlessly with its help. It is also independent of HTML and can be used with any XML-based markup language.

Bootstrap CSS the website uses CSS bootstrap framework to make the website responsive and offers 4 different color schemes for the website viz. orange, blue, yellow, green.

JavaScript is an object orient programming language designed to make web development easier and more attractive. In most cases, we have used JavaScript to create responsive, interactive elements for web pages, enhancing the user experience. It is executed on users' machine when they access the page, meaning that anything you can do in JavaScript will not add processing strain onto your server. It can also load content into the document if and when the user needs it, without reloading the entire page it is referred as Ajax. JavaScript can enhance the interfaces HTML gives us. While it is nice to have a text input box you might want to have a combo box allowing you to choose from a list of preset values or enter your own. Using JavaScript, you can enhance a normal input box to do that.

Creating confirmation boxes

When you enter your information into an online form and a confirmation box pope up, asking you to press "OK" or "Cancel" to proceed. For a number of operations for example: reservation confirmed.

Storing new information

JavaScript is particularly useful for assigning new identities to existing website elements, according to the decisions the user makes while visiting the page.

```
function updateFirstname() {  
    let Firstname = prompt('First Name');  
}
```

PHP is a recursive acronym for "PHP: Hypertext Pre-processor". PHP is a server-side scripting language that is embedded in HTML. It is used to manage dynamic content

databases, session tracking, even build entire e-commerce sites. It is integrated with a number of popular databases, including MySQL, PostgreSQL, Oracle, Sybase, Informix, and Microsoft SQL Server. PHP is pleasingly zippy in its execution, especially when compiled as an Apache module on the Unix side. The MySQL server, once started, executes even very complex queries with huge result sets in record-setting time. PHP is very easy to use and it easily connects with the database (MYSQL). We have designed two different forms using PHP in our website they are:

Booking form

This form contains the details of the customer who wishes to book table in the restaurant. It contains the following fields:

- NAME- This will contain the name of the customer who is booking the table on behalf of his group/family/himself.
- Contact no.- This will contain the contact number of the person who is booking the table.
- Email ID- This will contain the mail ID of the respective person.
- No. Of Diners- This will contain the number of persons coming to the restaurant.
- Date- It will contain date on which customer wants to book table.
- Time- It will contain time for the booking (lunch/Dinner).
- Preferred Food- This will contain the preferred food type of the customer.
- Occasion- It will contain the occasion of the booking (birthday/anniversary/regular dining/etc.)

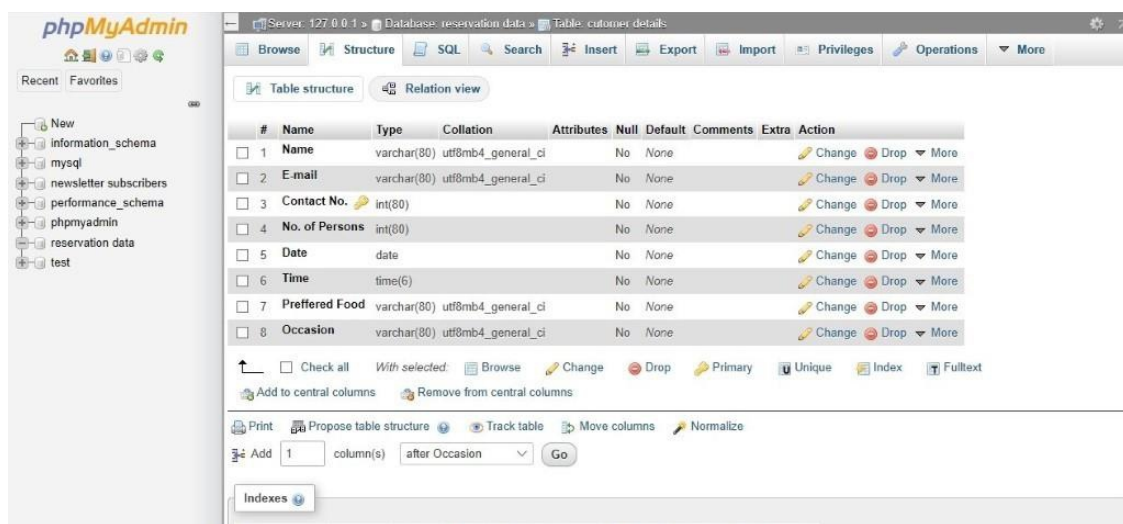

Fig 1 myAdmin Interface

Newsletter Form

There is section in the website which will have a form for the customers who are willing to subscribe for the newsletter of the Restaurant. It contains only one field given below-

- **Email ID-** This will contain the mail id of the customer who wants to join the newsletter of the restaurant.

III. Limitations and future scope

Crashes and Uptime

Down time can be a very serious issue for a restaurant's website. If the website is constantly crashing or unavailable for some reasons then the customers will not be able to find their desired information in time and could choose a different restaurant or be dissatisfied with the restaurant impacting the good will and the brand image of the restaurant. And to avoid such issues a good Web-Hosting service is needed.

The world has become digital and so has the restaurant industry. So, would you want to come to the forefront and embrace technology through a restaurant website?

The future scope of restaurant website is prominent. As of the current COVID-19 pandemic booking tables beforehand at your phone's conveniences will help maintain order, will help avoid forming of large crowds, avoids confusion and many other things which has a large application in the near future and can be seen being adopted by a lot of knows restaurants. To future proof this plan we have also created the website in such a way which is easy to update, and changes can be made based upon customers reviews.

IV. Result

This website is designed to ease the work of restaurants as of the current COVID-19 pandemic no one would risk their lives for being in queues to book tables. This website has straight forward option of reservation and selecting the kind of view and menu one desires. The use of HTML, JAVASCRIPT, CSS has enhanced and decorated website precisely for everyone to make it convincing and rudimentary yet appealing.



Fig.2 Home Page

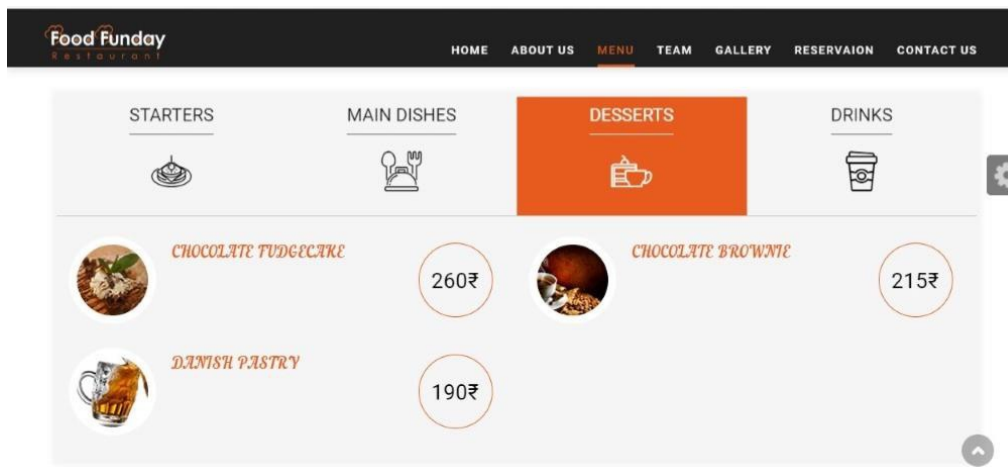

Fig 3. Items

V. Conclusion

This project concludes "A restaurant website" based on user's need and is user centred. The system is developed in considering all issues related to all user which are included in this website. Wide range of people can use this if they know how to operate android smart phone. Various issues related to Reservation of tables and menu; price of the dishes will be solved by providing them a fledged website. Thus, implementation of this web-site is done to help and solve one of the important problems of people. The website is very user -friendly, very easy to get into and that is why it help save a lot of time and efforts. It gives information needed in making reservation of tables for customer. The Foody Funday website application made for restaurant can help restaurant in modifying its data and it is also made for admin so that it helps admin in controlling all the modification. Also, with a food menu online, deciding the orders are done easily. The restaurants can even customize online restaurant menu and upload images easily. Having a restaurant menu on internet, potential customers can easily access at their convenience. Thus, an automated food website is presented with features of feedback and wireless communication. The proposed website would attract customers and adds to the efficiency of maintaining the restaurant and mess reservation sections.

VI. Acknowledgement

We are thankful for the constant encouragement; support and guidance from all teaching staffs of Computer Science Department which helped us get through a lot of hardship and has made the completion of this project a possible. We would like to extend our sincere esteems to all staff in laboratory for their support as well.

References

- [1] <https://www.w3schools.com>
- [2] <https://www.tutorialspoint.com>
- [3] <https://www.thecompanywarehouse/limitations>
- [4] <https://medium.com>the-scope-of-restaurant-website>
- [5] <https://internetingishard.com>introduction>

Collision Prevention and Avoidance Mechanism

Ranvijay Singh Tawar, Daksh Mathur, Dishant Sharma, Banu Pratap Singh

*Students, BCA III, Department of Computer Science
St. Xavier's College, Jaipur*

Abstract

Collision prevention is critical for navigation safety at sea. At early ages, researchers aimed at developing navigational assistance systems for enhancing situational awareness of human operators as human is at the core of collision avoidance. Recently, autonomous vehicles have gained a remarkable amount of attention with a focus on solving collision problems by machines. This paper provides an overview of collision prevention techniques based on the three basic processes of determining evasive solutions, namely, motion prediction, conflict detection, and conflict resolution and various key technologies for unmanned ships. The strengths and weaknesses of different methods for these three fundamental processes are discussed.

Keywords: *Collision Avoidance, Navigation, conflict detection, conflict resolution.*

I. Introduction

Collision Avoidance is a process in which one ship (manned or unmanned) departs from its planned trajectory to avoid a potential undesired physical contact at a certain time in the future. The ship under control is called Own-Ship (OS). Obstacles include stationary obstacles and moving obstacles such as Target-Ships (Tss).

Ship collision is an imperative task for navigation safety at sea. Due to the high frequency and severe consequences of collisions, researchers have paid much attention to related this and various kinds of techniques aiming at preventing collision accidents have been developed. From numerous accident reports and investigations, researchers share the common knowledge, i.e. human factor is the main cause of ship collision accidents (Chauvin, Lardjane, Morel, Clostermann, & Langard, 2013). Therefore, existing collision prevention technologies are mainly from two perspectives, i.e., assisting human on board and eliminating human factors. Enhancing the situation awareness of Officers on Watch (OOW) on board is a classical research subject from the 1950s (Tam, Bucknall, & Greig, 2009).

Many techniques were applied to support the OOWs on board, e.g., ship domain, automatic radar plotting aid, etc. The unmanned ship with an autonomous system is usually defined as an Autonomous Surface Vehicle (ASV). With the fast development of robotics, artificial intelligence, etc., ASVs have gained a remarkable amount of attention in recent years.

This paper aims at collecting developments of collision prevention techniques either for manned ships or unmanned ships.

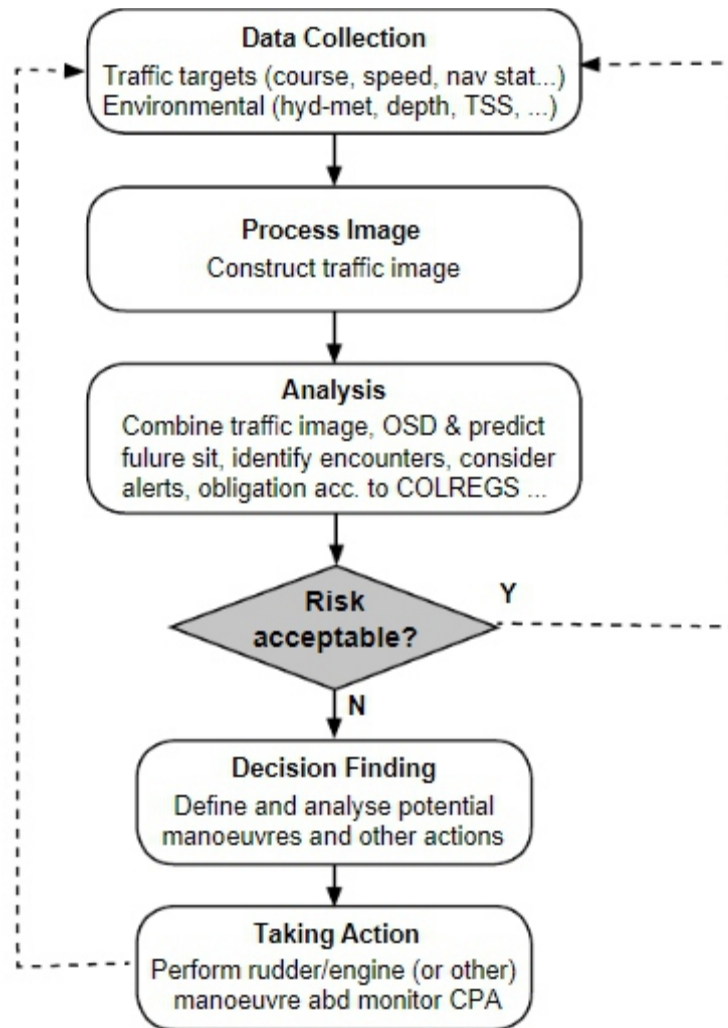
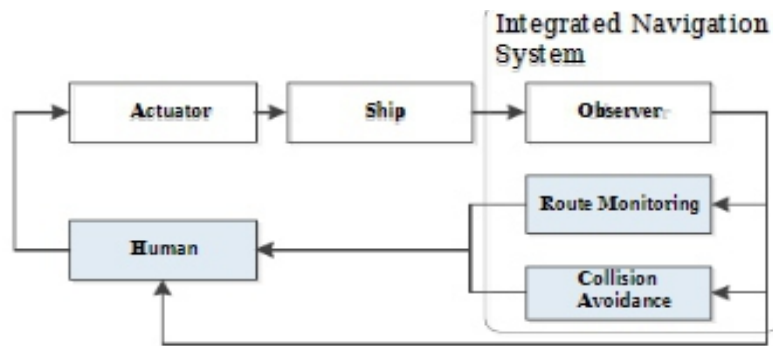

Fig. 1 Collision Prevention Mechanism

The collision prevention problem contains two sub-problems: “conflict detection” and “conflict resolution”. Solving the conflict detection problem is to determine whether the ship is in danger and when to take evasive actions. Solving the conflict resolution problem is to answer the question of what actions should be taken to prevent collision.

The data/information flows in a manned ship, and an unmanned ship during collision avoidance are separately presented in Fig. 1.



(1) the decision process in a manned ship

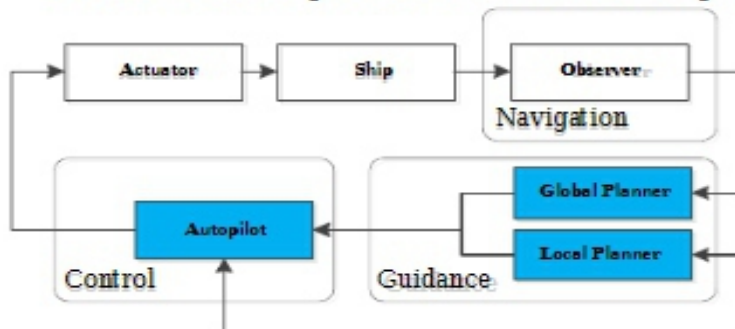

(2) the decision process in an autonomous ship

Fig 2 Decision Process in Manned and autonomous ship

When the ship observes the positions of Target Ships (TSs) at present, it estimates the possible positions of these ships in the future and their corresponding collision risks. Based on the estimations, the OS might decide to keep its current route or to find a new collision-free solution. The process of collision prevention and its information flows in the manned and unmanned ship can be abstracted as Fig. 2.

Five components are included:

- Observer, which contains various sensors offering data to support other modules;
- Motion Prediction module, which estimates the future trajectories of the Own Ship (OS) and the obstacles
- Conflict Detection module, which checks collision risk and launches collision warning if necessary;
- Conflict Resolution module, which determines the evasive solutions and then,
- Actuator, which implements the solutions.

II. Models for Collision Avoidance Methods

The “Motion Prediction”, “Conflict Detection” and “Conflict Resolution” are the main focuses of the collision avoidance system.

(a) Motion Prediction

Motion prediction is a fundamental module for ship collision avoidance, which contains a process that predicts the trajectories of the OS and obstacles. When the OS encounters with potential dangers, the predicted trajectories are used to determine the collision risk for

conflict detection. Moreover, when the OS determines a resolution, the predicted trajectories are also needed in the collision risk check.

The motion prediction usually relies on the mathematical expression of the system, i.e., motion models of the ship. Thus, the workspace of the ship is the horizontal space, i.e., $W = R^2$, and the configuration space (C-space) consists of position and orientation, i.e., $C = R^2 * S^1$.

According to the constraints used in modelling, the motion models are categorized as holonomic models (constraints on configurations only) and non-holonomic models.

Holonomic model

The simplest way to describe the ship's motion is based on the assumption that the ship is a holonomic vehicle which moves freely in a horizontal plane. Two versions of formulations are found.

$$\begin{cases} \dot{x} = u_x \\ \dot{y} = u_y \end{cases} \quad \text{OR} \quad \begin{cases} \dot{x}(t) = u \cos \psi \\ \dot{y}(t) = u \sin \psi \end{cases}$$

Where u_x and u_y are components of ship speed w.r.t. the earth; u is resultant speed and ψ is heading of the ship.

In the trajectory prediction of the TSs, Equation (1) is noted as constant velocity model (X. R. Li & Jilkov, 2003) which is widely used, then u and ψ are the observed speed and course of the Tss.

Kinematic model

The holonomic model ignores constraints on tangent C-space, e.g., acceleration of linear and angular speed. Thus, in some studies, kinematic motion models are proposed. A standard form of kinematic models is shown as follows:

$$\begin{cases} \dot{x} = u \cdot \cos \psi \\ \dot{y} = u \cdot \sin \psi \\ \dot{u} = a_t \\ \dot{\psi} = a_n / u \end{cases}$$

Where (x, y) , u , ψ are the position of the ship, speed, and heading angle; a_t and a_n are tangential and normal accelerations, respectively. This model comprises various kinematic models (X. R. Li & Jilkov, 2003), such as “unicycle” model, “dubins car” model, and “simple car” model. In these models, “dubins car” model ($a_n=0$) (e.g., (Hvamb, 2015; Vincent, 1977)) and “simple car” model (e.g., (S. Fossen, 2018)) have been used in maritime studies.

Dynamic model

Kinematic models ignore the ship's mass that has great impacts on ship motion. The accelerations in each direction which have complex mechanisms are not properly addressed, as well. Therefore, researchers introduced kinetics relations into a kinematic model to increase the accuracy of prediction.

Vectorial representation for marine vehicle

A widely used dynamic model is described in a compact vectorial setting, which contains two formulations: one describes the kinematic relations; the other shows the kinetic equations. The kinematic formulation is

$$\dot{\eta} = R(\eta)v, \text{ where } R(\eta) \text{ is a rotation matrix, } \eta = (X, Y, \psi)^T \text{ and } v = (u, v, r)^T$$

The kinetic relation is then formulated as (T. I. Fossen, 2002):

$$M\dot{v} + C(v)\dot{v} + D(v)v + g(\eta) = \tau + w(t),$$

where M , C , and D denote the mass, Coriolis, and damping matrices; g and w are vectors of restoring forces and disturbance; τ denotes an input vector contains surge force, sway force and yaw moment

Mathematic Model Groups (MMG)

MMG model is another dynamic model, which is used in manoeuvrability prediction. Instead of using the forces as inputs, the MMG employs rudder angle and propeller revolutions as the inputs and models the responses of hydrodynamic forces to different inputs by empirical formula method. In this way, more details of rudders and propellers are considered, e.g., the specifications of rudders and propellers. Thus, this model is usually used in the theoretical analysis of ship manoeuvrability. The application of this model in collision prevention presented in (He et al., 2017; S. J. Li, Liu, & Negenborn, 2019; Y. Xue, Lee, & Han, 2009). This model can produce a relatively accurate trajectory, while the cost is high. It requires a better understanding of ship hull, rudder, and propeller. Moreover, since the relationships between control inputs and forces are nonlinear and complicated, this model is less popular in the design of ship controllers and observers. Researchers prefer to use some simplified model based on MMG to predict ship's trajectory.

(b) Prediction of trajectory

Prediction of the OS's trajectory

In an ideal case that the control inputs and motion model of the OS are known. The simplest way is to assume that the OS is a holonomic vehicle, which is popular in many collision preventions studies. However, the errors between the predicted trajectory and the real trajectory are huge due to this unrealistic assumption. Thus, some researchers consider the non-holonomic constraints and use kinematic models in prediction to make the predicted trajectory closer to the real trajectory. One advantage is its concise form, while the accuracy of the prediction is still the issue. Therefore, nowadays, many researchers employ either the dynamic model or simplified dynamic model in trajectory prediction.

Due to the complicated form of the equation, the analytical solutions are usually infeasible, and the numerical method is usually needed, e.g., Runge-Kutta methods, etc.

In other cases, researchers face with more practical problems, such as uncertainties on motion models and parameters. Then, some model identifications are needed to obtain the motion model. Moreover, a challenging issue is considering noise and errors in predictions. In this case, studies usually applied Kalman filter (or its variations) in trajectory prediction.

Prediction of the TS's trajectory

Since the information of the TS is insufficient for the OS, e.g., parameters of motion model, inputs to the system, etc., the prediction of the TS is more challenging than that of the OS. Due to these uncertainties, researchers usually prefer to use simple models, such as the

holonomic model and kinematic model. The simplest way to predict the trajectory of the TS is based on the assumption that the TS keeps its velocity and neglects environmental disturbance. It is widely used but less accurate for collision avoidance. A more reasonable approach is considering the uncertainties of models, inputs, and disturbance. The methods for predicting the trajectory of the TS can be categorized into three groups according to the knowledge of the TS.

- **Physics-based methods** predict the motion of the ship only depending on the laws of physics, while the existing studies either ignore the control inputs or treat the manoeuvres as white noise. KF is a preferred technique used to consider these noises and give the best guess of the ship's trajectory in many studies. To handle the nonlinearities and uncertainties of these motion models, the variations of the Kalman filter are used, e.g., extended Kalman Filter (S. Fossen, 2018), Particle Filter, Interacting Multiple Model Kalman filter, probabilistic filter (Eriksen, Wilthil, Flåten, Brekke, & Breivik, 2018), etc. Although these methods can predict the trajectory of the ship in a short period, they cannot predict the changes in trajectory due to the changes of manoeuvres.
- **Maneuver-based methods** take the manoeuvres of the ship into account, i.e., navigational intention, which is learned/ estimated from historical traffic data or by the protocols for ship encounter situations, e.g., COLREGs. Algorithms learn the behavioural patterns of ships in a certain area from massive traffic data and then use these patterns to support the prediction (Scheepens, van de Wetering, & van Wijk, 2014).

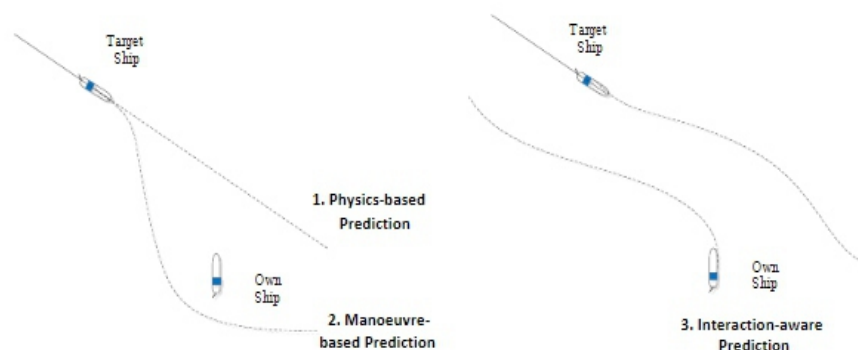

Fig. 4 An illustration of different predictions methods

III. Conflict Detection

Conflict detection refers to determinations of whether and when evasive actions should be taken by the OOW. The core of this process contains a collision risk assessment, which triggers an event that either requires human to notice collision dangers or asks the human/machine to find a collision-free solution.

Conflict detection in practice includes:

- Identify potential collisions and launch an alarm for the OOWs on board or operators in Vessel Traffic Service (VTS)
- Trigger the autonomous system on board to find evasive actions
- Evaluate the risk of alternative paths or evasive actions

IV. Conflict Resolution

Conflict resolution is the core of collision prevention, which determines collision-free solutions for the ship. Many methods have been developed for this purpose.

- Rule-based method uses “If-then” rules to guide the collision avoidance process;
- Virtual vector method generates a virtual vector field to determine the motion of the ships;
- Discretization of solutions with collision check method searches the discrete solution-space and finds a collision-free solution or an optimal solution.
- Continuous solutions with collision constraints method formulate collision as constraints and find the optimal solution in continuous space;
- Re-planning method formulates the collision avoidance as a path planning problem and searches collision-free path in free configuration space;
- Hybrid method combines some of the previous methods in collision avoidance.

V. Unmanned surface vessel collision avoidance key technology

Starting from the practical application of collision avoidance of unmanned surface vessel at sea, environmental perception is the basis of unmanned surface vessel collision avoidance technology. Environmental perception refers to collecting the environmental parameters of surrounding environment and surrounding objects by means of sensor acquisition as unmanned intelligent devices. Information such as relative distance, angle and motion state is obtained. The environmental information of the unmanned surface vessel's navigational waters is obtained through environmental perception, and then the information is analysed and identified by the processing system, and then the collision avoidance instruction is made. There are five main types of existing strategies:

(1) Hydroacoustic sensing equipment: Equipment including underwater acoustic sensors, hydroacoustic sonar, etc., uses the characteristics of sound waves propagating in water, convert sound information into electrical signal processing, to accomplish tasks such as underwater object detection, navigation environment perception, etc. This type of perceptual equipment is currently one of the unmanned surface vessel infrastructures.

(2) State-aware devices: Equipment including GPS, magnetic sensors, inertial navigation systems, etc., can directly obtain information such as the position, navigational attitude, and steady state of the ship. This kind of equipment is mainly used for positioning the ship itself and maintaining a stable navigation state. Determining the state of unmanned surface vessel motion is an important condition for collision avoidance decision-making.

(3) Radar: The existing ship borne radar is divided into various categories: ultrasonic radar, laser radar, millimetre wave radar, etc. The radar device transmits a specific signal to the surrounding environment, and then identifies the location of the object according to the received echo signal. The radar can effectively detect targets within a certain distance, and its performance is stable and accurate. But the shortcoming is that there is a blind zone, and the target information acquired is not accurate enough. The ME70 mapping unmanned surface vessel launched by China Yunzhou Science and Technology Company mainly uses laser radar to detect obstacles.

(4) Image recognition sensor: The image recognition sensor can directly receive environmental information, and after preliminary digital processing, the information is directly submitted to the system for the further procession. Suitable types of targets for

imaging at sea include visible light, infrared, low light, laser fog, etc. Visible light image recording is mainly used in the case of good light. Infrared night vision, laser and fog recording are for night and special weather conditions such as fog. Its advantages are large amount of information acquisition, low cost, high efficiency, and real-time.

(5) Fusion sensor:

This type of sensor combines radar and machine vision sensors to obtain more accurate and diversified detection information. The C-Target unmanned surface vessel developed in the United Kingdom. It can detect the navigation environment under complex conditions and complete autonomous navigation through the combination of radar, vision sensors and infrared sensors. Converged sensors that take into account the advantages of multiple types of sensors are also trends in the development of environmentally aware devices.

At present, the most widely-used obstacle avoidance sensing scheme is the application of radar as the main detecting device, and the state sensor as an auxiliary, limited by the development of the technology, the practical application of the image recognition sensor is not widely. Compared with other sensing technologies, optical image-based sensing technology is more likely to effectively distinguish surface targets because optical images contain more detailed information on target regions. It has been designed and developed by more and more researchers. Thus this technology has an important position in the field of autonomous navigation and collision avoidance.

VI. Image recognition system principle

The navigation environment image information acquired by the ship borne equipment need to be processed and analysed in advance, and then identified and classified. Finally, the identification conclusion is obtained based on these works. The image recognition system flow is as follows:

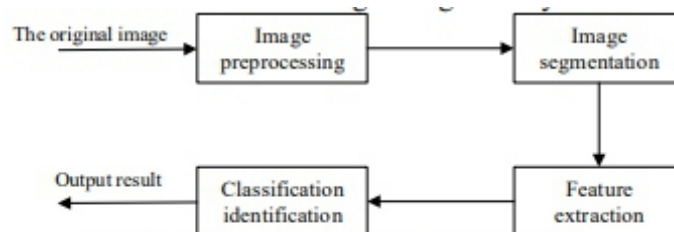

Figure 1. Image recognition system flow

(a) Image Pre-processing

In the image acquisition process, random noise generated by various factors will affect the later recognition. Therefore, the original image should be processed in advance. The pre-processing includes geometric transformation, brightness transformation, filtering, image restoration, etc., in order to improve the image data, suppress unwanted deformations, and enhance important image features for later classification and identification.

(b) Image Segmentation

Image segmentation is a key step in image recognition. After segmentation, the unrelated image background is removed, leaving important parts of the original image that need to be identified. This step can make the extraction of later features more accurate and efficient. Commonly used segmentation methods are based on threshold, edge-based, region-based,

cluster-based analysis, wavelet-based transformation, mathematical morphology, artificial neural network-based, genetic algorithm-based segmentation methods, etc.

(c) Feature Extraction

Feature extraction is to further analyze and understand the image data, extract the information related to the classification in the data, and select effective and identifiable features from a large number of features to achieve the purpose of reducing the recognition difficulty and improving the recognition speed. The common identification features of the recognition targets involved in the actual navigation environment of the unmanned surface vessel include geometric features, moment features, transformation features and SIFT features.

(d) Classification and Identification

In the feature space, the features that have been processed are subjected to regular contrast recognition. This step can be performed by using a variety of classifiers, such as KNN classifiers, Bayesian classifiers, and neural network classifiers [12].

VII. Development trends

With the continuous development of sensing technology, information technology and automatic planning technology, and the increasing emphasis on water transportation safety, countries have invested a lot of manpower and material resources to develop image recognition technology for unmanned surface vessel collision avoidance. Delay, high recognition rate, high recognition domain and high reliability will become the trend of image recognition technology in the collision avoidance of unmanned surface vessel [24].

(1) Low latency

The speed of modern small ships is constantly increasing, and the requirements for self-identification are also improved. The identification technology must respond in time to effectively warn dangerous information and set aside sufficient time for operation and risk avoidance. The lower the response delay, the better the actual use effect, so reducing the delay has always been the focus of image recognition technology development and optimization.

(2) High recognition rate

The water transportation environment is complex and the climate is changeable. In some special extreme weather conditions (such as storms, low-altitude fog, etc.), the visibility is low, and it is easy to produce overlapping images of ships in the distance, water reflection on the surface of the water, and bumps in the ship. In the case of shadows, the image acquisition equipment can obtain poor image quality, the recognition difficulty is increased, and the speed and accuracy are reduced. To solve this problem, researchers are constantly optimizing algorithms and analysis mechanisms (such as low-Resolution image enhancement, foggy environment image classification processing technology, etc.), in order to maximize the recognition accuracy and recognition rate in poor environments, and enhance the environmental adaptability and stability of ship image recognition technology.

(3) High recognition domain

In reality, the number of ships entering the estuary and tributary gathering places is large, and it is easy to generate route conflicts, which is a high-level section where

collision accidents occur. Image recognition technology needs to identify multiple ship targets, and it must ensure accuracy under the premise of rapid identification. Therefore, the wider identification domain is very important and has a great effect on dealing with complex navigation condition.

(1) High reliability

Ship collision avoidance systems need not only accurate predictability and high degree of intelligence, but also adapt to the harsh environment of maritime change, in some extreme environments (such as strong natural electromagnetic interference, thunderstorms, severe weather, etc. The stability and reliability of image recognition technology itself have been improved. Therefore, the development trend of ship image recognition technology is to improve the ability of identification and enhance the stability of analysis and reliability to adapt to complex navigation environments.

VIII. Conclusion

With the improvement of electrification level, the advantages of intelligent, low-cost and real-time video surveillance, it can be applied to the unmanned surface vessel's autonomous navigation and collision avoidance. The image processing algorithm can detect the water surface target and provide a certain way and valid information to avoid collision and identification. Intelligence and high speed have always been the development direction of modern ships. The improvement of ship speed has put forward higher requirements for ship intelligence. Image recognition technology applied to unmanned surface vessel autonomous navigation and collision avoidance is important for improving the autonomy of unmanned surface vessel. Significance is also an important direction for the intelligent development of unmanned surface vessel in the future.

References

- [1] Qin Li, unmanned surface vessel: Coming day, China Ship News, 2014.08.22.
- [2] Tianbo Ma, Overview of Environmental Sensing Technology for Driverless Vehicles, Automobile and Driving Maintenance: Maintenance Edition, 2017(5): 122-123.
- [3] Zhenyi Chen, Research on Navigation State Perception System of Small Surface Unmanned Vessels, Wuhan University of Technology, 2014.11.
- [4] Dajun Sun, Cuie Zheng, Discussion on the development trend of underwater acoustic navigation and positioning technology, Journal of Marine Technology, 2015.03.
- [5] Dickmann J, Appenrodt N, Klappstein, Making Bertha See Even More: Rader Contribution, IEEE Access, 2015, 03.
- [6] Mingming Luo, Feng Zhu, Dongsheng Wang, A review of the research on automatic image recognition of ship images based on computer vision, Software Guide.2018.06.
- [7] Heng Xu, Research on maritime target detection technology based on shipborne radar image, Wuhan University of Technology, 2012.05.
- [8] Shengnan Zhang, Multi-sensor based unmanned surface vessel environment perception research, Hainan University, 2011.08.
- [9] Wenjing Zeng, Research on surface target detection and tracking of unmanned surface vessel based on optical vision, Harbin: Harbin Engineering University, 2013.03.

- [10] Wuyi Zhang, Qiangsong Zhao, Dongyun Wang, The status quo and development trend of machine vision, Journal of Zhongyuan Institute of Technology, 2008.02.
- [11] Milan Sonka, Vaclav Hlavac, Roger Boyle. Image Processing, Analysis and Machine Vision, 4th ed. Tsinghua University Press, 2016.
- [12] Wei Li, Research on surface motion recognition technology based on artificial neural network, Harbin Engineering University, 2007.01.
- [13] Siguang Zong, Jiangan Wang, Qishui Chen. A New Algorithm for Infrared Weak Point Target Detection in Complex Background of Sea and Air, Optoelectronic Engineering, 2005, 32(4): 9-12.
- [14] Jun Liu, Infrared motion ship detection and tracking for ship collision avoidance warning, Optoelectronic Engineering, 2010.09.
- [15] Bao, Xinfeng, Zinger, Svitlana, Wijnhoven, Rob, de With, Peter H.N. Robust Moving Ship Detection Using Context-based Motion Analysis and Occlusion Handling, SIXTH INTERNATIONAL CONFERENCE ON MACHINE VISION, 2013.
- [16] Kaido, Naoya, Yamamoto, Shigehiro, Hashimoto, Takeshi, Examination of Automatic Detection and Tracking of Ships on Camera Image in Marine Environment, 16th Techno-Ocean Conference (Techno-Ocean), 2016.
- [17] Ying Tong, Research on Key Technologies of Stereo Vision Based on Infrared and Visible DualBand Images, Tianjin University, 2015.11.
- [18] Huntsberger, Terry, Aghazarian, Hrand, Howard, Andrew, Trotz, David C, Stereo Vision-Based Navigation for Autonomous Surface Vessels, JOURNAL OF FIELD ROBOTICS, 2011.
- [19] Dairi, Abdelkader, Harrou, Fouzi, Senouci, Mohamed, Sun, Ying, Unsupervised obstacle detection in driving environments using deep-learning-based stereovision, ROBOTICS AND AUTONOMOUS SYSTEMS, 2018.02.
- [20] Baocai YIN, Wentong WANG, Lichun WANG. Review of Deep Learning Research, Journal of Beijing Polytechnic University, 2015(1):48-59.
- [21] Guihuai Wang, Shuo Xie, Xiumin Chu, Tianjiao Luo, image recognition method for vessels in front of surface unmanned surface vessel based on deep learning, Ship Engineering, 2011.04.
- [22] Khellal, Atmane, Ma, Hongbin, Fei, Qing, Convolutional Neural Network Based on Extreme Learning Machine for Maritime Ships Recognition in Infrared Images, SENSORS, 2018.05.
- [23] Zhang, Xiangli, Wang, Hesheng, Chen, Weidong, Vessel Detection and Classification Fusing Radar and Vision Data, 2017 SEVENTH INTERNATIONAL CONFERENCE ON INFORMATION SCIENCE AND TECHNOLOGY, 2017.
- [24] Ziyang Ma, Yan Zhang, Hengtao Wang. Research status and development trend of shipborne water pollutant identification device, China Ship Repair, 2018.02.
- [25] Ma, Zhongli, Liu, Quanyong, Hao, Chen, Yuwei, Liangliang, A Classification Method of Fog Image for USV Visual System, 34TH CHINESE CONTROL CONFERENCE, 2015.
- [26] Libin Yan, Feature extraction and identification of inland waterway boats based on machine vision, Hunan Normal University, 2015.03.
- [27] Zhongyuan Chen, Application Research of Electronic Chart in Collision Avoidance Technology of Integrated Ship Bridge System, Ship Science and Technology, 2016.03.

Join kudrat: A Real-time Anonymous Communication System

Angad Srivastav, Chirag Mathur

*Students, BCA III, Department of Computer Science
St. Xavier's College, Jaipur*

Abstract

“Join Kudrat” is a web-based application which may be used to interact with people and which gives a safe and secure platform to diverse groups to express their opinions under the protective garb of anonymity. It can also be used to create a meeting space for discussion or any business deal. It allows for fast paced communication as it does not rely on any form of login authentication. It simply requires the end user to enter their name (as per their desire) and the room that they wish to enter in order to communicate. Achieving this objective is challenging as this type of application usually requires for user's data to be collected and then represented. Kudrat does not store any user data and still achieves the vaunted objective of expeditious communication. It also solves the problem of storage consumption since it is a web-based application that works on the world wide web. It does not store any cache or cookies and requires minimal RAM storage for its operation.

Keywords: *Anonymous, Communication System, RAM, online community, chat application.*

I. Introduction

“There are two types of people who like to remain anonymous: those who spread vicious lies, and those who tell the absolute truth.” –Anonymous

Anonymity is the condition of being anonymous. Living in the modern world an individual is constantly profiled. We hand over our sensitive information to proper authorities and corporates conglomerates under the presumption that they will keep this information safe. But this is further from the truth. The online community is ever-changing and is adapting as more of the world joins. At times such as these, it is important to uphold the principles of one's anonymity and privacy. Free speech and anonymity have always been part of the free world and have been the topic of several heated discussions. There are two sides to this discussion - a side that believes that people do not need to hide behind an anonymous identity if they have nothing to hide and another that believes that in order to share information sometimes it is a necessity to hide.

II. Background and Literature Study

Anonymous communities began proliferating on the internet in the beginning of 1988. The topics discussed by these communities varied from controversial, personal, to possibly offensive. With the passage of time anonymous newsgroups and other pro-anonymity communities started gaining some traction. In 1992 Chypherpunk Group's remailer service was a specially made server that would take messages with embedded instructions to their destination and forward them without revealing who the sender was. In today's time, a basic way of hiding your identity online could be to send a message from a fake or throwaway account. But this still leaves one vulnerable as the IP address is still traceable. VPN's were introduced for the purpose of maintaining one's online presence hidden to bolster one's online privacy and security. VPN services have become increasingly popular in recent years, but not all are completely anonymous. Technology has had substantial growth in data protection and anonymity online. There now exist tools to encrypt and decrypt files using

dedicated keys. Encrypted files have been used by journalists to transfer sensitive information which even if stolen in transit cannot be used in a manner contrary to the intentions of the sender. In a civil society, it is necessary to facilitate the exchange of ideas and thoughts for the development and prosperity of society as a whole. In a society where people are unique and differ in their viewpoints, it can become quite complicated and even dangerous to say something which might appear as offensive to someone else or to a particular group. Therefore, it might be in the best interest of everyone to exchange ideas in an environment where there exists anonymity. It is in fact essential to be able to express certain views without revealing one's identity. Anonymity also serves a key learning function, allowing students to ask questions without fear of criticism of their peers. Anonymity also makes it easier to report activities. People report crimes much easily if they know that the perpetrators will never know it was them who reported. Whistle-blowers usually give data that they have obtained, to journalists under pseudo-names and have no desire to be named for the data that they have revealed. Journalists never reveal the name of their sources as doing so might put the source at a risk. Anonymity online can lead to an environment free of discrimination, sexism and racism as the individual's name, gender, race will play no factor in the discussion and will have absolutely no effect. This will eventually result in a much sustainable and healthy discussion. Anonymity supports the fundamentals of freedom of expression and that of speech. It gives people an outlet to express what they feel like without being worried about what their ideology is being interpreted as. It allows for open discussions where people think and then respond rather than just reply.

The purpose of this section is to summarize the developments that took place within Kudrat and put them in a larger scientific and technological context.

Here, in this paper, design of an anonymity-based chat system has been proposed. The paper unravels the concerns of online anonymity and the issues pertaining to the storage of data and meta-data of the users. The mechanism with which numerous other online applications collect user's data during their online activities is also discussed here.

III. System overview

Kudrat is a real-time chat application which does not rely on storing user messages in order to transmit them. It uses modules like Socket.io to send messages on the fly. It also does not store user information like their name, email or phone number in order for them to use this service. The users only need to provide any name of their choice at the time of login into the system's chat room. This helps in prevention of multiple data related problems like Data Bleach, Data Theft and Data as a commodity.

Since no data is stored by this application it cannot be retrieved by unwanted users. There are no open-ended links which can be retrieved hence no data bleaches. And again, since there is no data storage on any database there is absolutely no possibility of data being used as commodities. Once a user quits out of a session the interaction that occurred is erased from the user's side and only remains on the users who are still active in the session.

All of this helps in maintaining privacy and anonymity of the user. The user can freely communicate his ideas and opinions without being worried for persecution that he/she might face. This allows for free exchange and open discussions in which all sorts of individuals divulge. Kudrat currently does not allow for transfer of medial files.

System requirements

Hardware Requirement

- Internet Connectivity
- Electronic Device

Software Requirements

- Browser

System design

System Tools

- HTML
- CSS
- JavaScript
- Nodejs
- Socket.io
- Emojify Module
- React.js

System's Key Modules

Login Page

User who wants to avail our services are invited to enroll for a free account in our portal with few simple steps, by providing username (as per the user desire) and the room name that they wish to enter in order to communicate with others. As Kudrat does not rely on any form of login authentication.

Service Module

When user sign-in in order to interact with others the program will check that the particular room name is already exist or not. If it is then user enters into the existing chat room otherwise program creates a new chat room and user can share it with others to join the same chat room.

IV. Proposed System Model

(a) System workflow

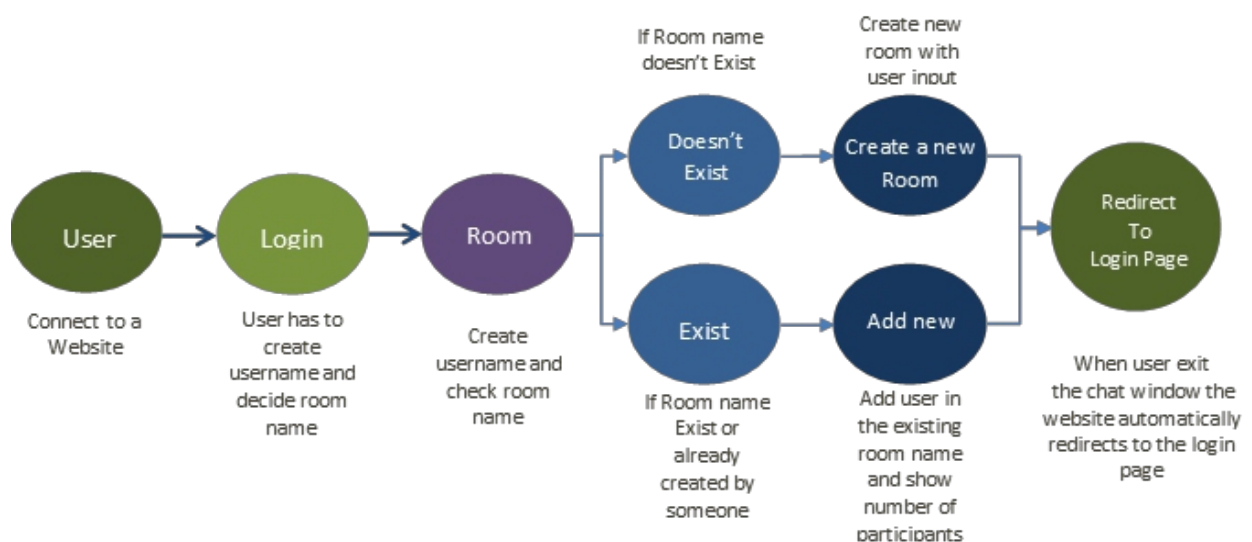

Fig 1 System Workflow

(b) Use case diagram

The Proposed system involves one actor which include only a User. User has to sign -up by username and room name to enter into the system’s chat room in order to communicate with others.

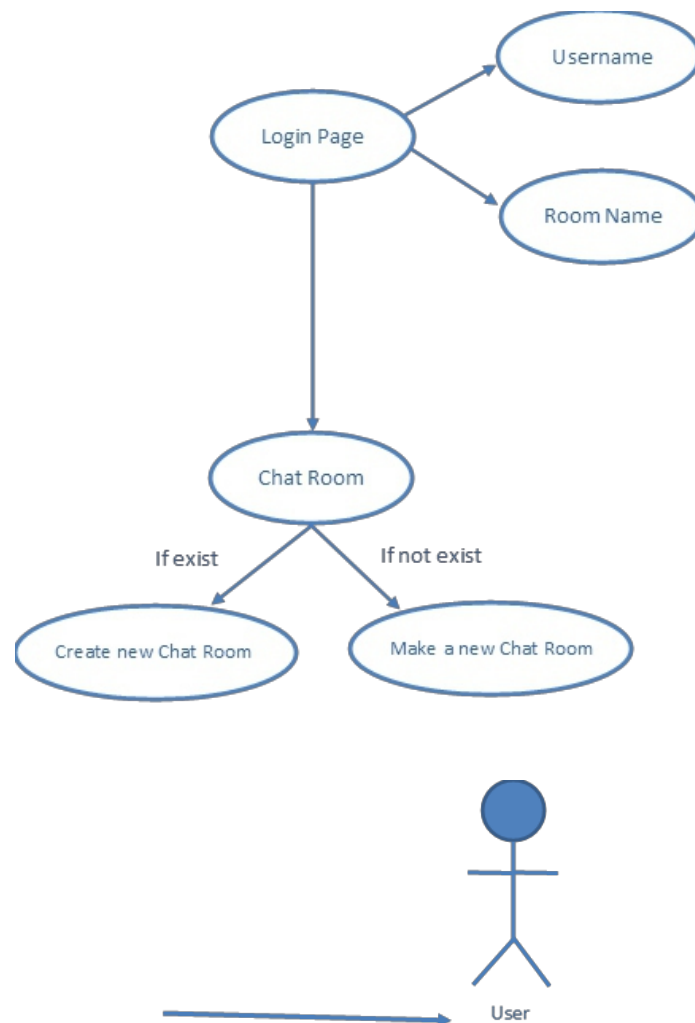

Fig 2. Use Case Diagram

Design methodology refers to the development of a system or method for a unique situation. Kudrat is a real-time chat application. In order for a real time chat application to execute its objective we first need to define its scope. The scope of the application is that the application will perform its natural tasks on any device that supports connectivity and has a browser. The browser must be able to transpile ES2015 or else the execution will fail. Since this is a chat application this will be a dynamic app rather than static.

After defining its scope work began on its front-end design. The front end was designed with react.js as it is a front-end library/framework with a rich eco system. React has components which communicate with one another and allow for transmission of data from one component to another. Every small division was divided into components. We have components for Chat box, login, details of chat box and much more. These components for all then fixed in a final component which was then rendering ReactDOM. We also loaded an emoji module in react. It is a module that allows for exchange of emoji on the application. If a user types in an emoji it will automatically convert it into an emoji and then transmit it to the end user. This makes the app more interactive and visually attractive.

Once the front-end is designed we work on the backend. The backend relies on node.js. The backend is where all the logical operations occur. Node.js has an index.js which is the main file for the server backend. This is where we add, remove and get users in a specific remove. Index is also responsible for responsible for transmitting the messages from one user to all the other users. The transmission of messages takes place through Socket.io. Socket.IO enables real-time, bidirectional and event-based communication. Socket simply emits the messages from one user to the chat box for all the other users. There is another file users.js maintains the records of the users in a room and if a user tries to enter a room where another user already exists with the same name he will be notified. It also handles when a user leaves the room. Updating the registry.

V. Results

The main objective of 'Join Kudrat' is to provide anonymity and privacy to its users. The system has provided the anonymity to its users. As the transmission is done through socket.io at the backend the chances of bleaches are minimal hence providing a greater rate of security and anonymity. The system does not ask users to go through any signup or login, and hence avoids metadata collection and facilitates non-transmission of user's credentials, eliminating the risk of data theft, data as a commodity and data bleach.

The system target users are the ones, who wish to remain anonymous and do not wish for their privacy to be invaded as they have a civil discourse where ideas and thoughts are exchanged without the fear of being persecuted for having ideas and thoughts different from a majority. These ideas sometimes might be unpopular but in any free society this will always be the risk you run into.

The app also was able to provide fast paced communication as it did not have any standard procedure of login/signup. It was a quick process of get in a room and simply communicates. The system prohibits exchange of any gore, sexual or ill-natured media content as it simply does not allow for media file transfer. This meant that the users can only have discourse in a textual manner and not any other form.

VI. Conclusion

Rude, inappropriate and offensive behaviour has been present on the internet long before the idea of anonymity in the digital context had even been considered. The best countermeasure against such harshness is to not pay any attention to it - to simply ignore the vile content one might come across on the internet. Anonymity may have its disadvantages but they are highly outweighed by the advantages it confers on people. To ask for zero anonymity because of the behaviour of a few individuals is equivalent to asking for a shutdown of roads because few accidents happen now and then. Freedom of speech must exist. And with this freedom, we are bound to have all sorts of problems attached to it. Unpopular speeches are a consequence of free speech but this should not stop us from practicing it.

References

- [1]Karina Rigby, Anonymity on the Internet Must be Protected (Ethics and Law on the Electronic Frontier, 1995).
- [2]Andrew Schnorr, Anonymity on the internet an investigation.
- [3]Dr. Keith Goldstein, Dr. Ohad Shem Tov, and Mr. Dan Prazeres, The right to privacy of the digital age (April 9, 2018).
- [4]Claudia Eckert and Alexander Pircher, Internet anonymity: Problems and solutions.
- [5]Steve gold, Getting lost on the internet: the problem with anonymity.

Hostel Management System

By Umang Choudhary, Bijoy K D, Yash Sonkiya, Aryan Sharma

*Students, BCA III, Department of Computer Science
St. Xavier's College, Jaipur*

Abstract

Hostel Management System is the system that is created to manage the student data, admission process, staff data, room allotment and the creation of receipt for the fees paid by the student who stay in the hostel. It also helps in maintaining visitors' messages. The model of the project is inspired by the difficulties faced by the people working in this field. It is often immensely time consuming and prone to faults in the data or even maneuvering the way to a particular record. We, as a team have taken an in-depth look at all the possible issues or problems that could cause the system to fail and have created a structure that to its core has been defined by thorough examination of the way a hostel works.

Keywords: *Hostel Management System, Interview, Record Review, Observation, Feasibility Study.*

I. Introduction

The existing system is based on manual work which means processes like maintaining registers and files for recording all the details of the system are done by hand. Physical books or registers are used for recording the entry and exit of the daily transactions such as visitors who are visiting the hostel or even dropping a message for a particular student, etc. In this similar fashion a fees master file and a bill Book or receipt Book is used to maintain the record for the fees collected from the students. Therefore, maintaining Staff and Student Information, Visitors information, Student Check-in and Checkout information, room allotments and all the things are done manually.

The Hostel Management System is developed to overcome most of the problems occurring in the manual system by computerizing the existing system. Computerized systems are more helpful in dealing with areas where any time of data recording process is concerned. A computer can hold large amounts of data in its storage devices and it can operate at very high speed. The user can put the entire information in the computer and will be able to perform any type of task which when done manually is tedious and time consuming.

The new system will have the ability to sort data according to the specific need and the basis of what the user wants from there database. Also, with the help of a computerized system if the user wants to access any single users' data from all the data there is stored in the system, he or she can automatically get the desired data by using keywords or typing the data type that is required, may it be student or staff or fees details, etc. in a fraction of second which is again time saving and efficient.

Our team also wanted to provide an easy to access and use interface for the users that will be constantly working around the Hostel Management System to reduce any type of incomprehensibility so that the system application is widely accepted

II. Methodology

Before getting into the technicality of Hostel Management System, the most important steps that were taken by the team are the feasibility of the project and to gather information and any knowledge on the topic.

A proper search strategy should be implemented for the appropriate work flow required to assess the situation of the existing system and its drawbacks. The following approach should be efficient to execute the task at hand:

Interview

Interviews allow the analyst to collect and gather the required information for the easy identification of problems from any individual or group who is the current user of the existing system or potential user of the proposed system. It could be a manager or an employee of the firm itself who provides the data for the proposed system. It may be time consuming but is the basic source of qualitative information and also uncovers any misunderstanding or indication of resistance to the proposed system.

Record Review

Every existing system consists of existing documents, forms and files which can be examined for the better understanding of the system.

Records like written policy manuals, Rules and regulations, Standard operating procedures used in Hostel Management System, Forms and documents and the format in which data is traditionally stored can be easily understood by the analyst and taken into consideration for the probable and most appropriate creation of the user interface as well as the back end processing

A good documentation system which can be instilled in the proposed system provides relationships and interaction between itself and the user. Analysts can also know about Hostel Management System structures, baseline activities, procedures which are followed by institutes and the flow of data. For example, a chart made for the Hostel Management System can greatly help in knowing the formal grouping of people in a department.

Observations

Observation can be done to bring out missed facts that might have been overlooked and create new ways to improve the existing procedures, duplicate work done inadvertently, etc. Observations may utilize a lot of time but they push a person to look at the picture in a different angle which may be rewarding in the future.

Observation gives analyst the opportunity to go behind the scenes in a Hostel Management System to look at a different angle and discover how things work in new areas of information. It may provide the analyst with information like alternate routes and procedures, interruptions in the normal flow of work, etc.

Observing an existing system while being present on spot provides a closer view of the working of a real system. An analyst can observe people, objects, documents and occurrences of events. Apart from this, figuring out the feasibility of a project helps to obtain an overview of the problem and to get a rough assessment of whether a feasible solution exists. This is essential

so that large resources shouldn't be committed to a project and then regretted later on. The three main feasibility assessments done by our team were as follows:

- **Technical Feasibility**

It determines whether the work that is supposed to be done for the project can be accomplished with the present equipment and procedures, existing software's technology and personnel available or there is a need for a new technology and what other alternatives will be required in the present work environment?

This will require a close examination of the present work station and understanding of the requirements, if any. The technical feasibility should ask questions related to the adequacy of available technology and hardware available on a computer and the operation time and support required to accomplish the task at hand.

Technical feasibility determines if the technology required for the proposed system is available or there is a need for an upgrade for the proposed Hostel Management System and Technical evaluation must also assess whether the existing system can be upgraded to use the new technology and whether the project can utilize the expertise of this new technology.

- **Economic feasibility:**

Economic feasibility looks at the monetary aspects of the proposed system. Economic feasibility is concerned if the project will have any return in terms of money. It determines whether it is worthwhile to invest the money in the proposed system because it is not worthwhile spending a lot of money on a project that will provide us with no returns. To test out the economic feasibility for a system, one has to measure every resource may it be an activity needed to implement the project or anything else in monetary terms.

- **Operational feasibility:**

Operational feasibility covers two aspects which are the technical performance aspect and other is the acceptance within the existing user base of Hostel Management System. Operational feasibility determines how the proposed system will fit in the current operations and in what it will create a new structure which will be accepted or not in the existing one. It may even affect jobs which should be taken into consideration beforehand.

Another factor to consider would be if the user can understand and work with the interface as well. If the user does not understand or is unable to work on the system further development is of waste.

III. Limitations

The limitations for the Hostel Management System are very few to begin with, but are as follows:

Power outage is one of the biggest drawbacks that could cause a hurdle in working with the following system as the user will not be able to access the database because of no electricity to boot up the computer

Another drawback to the Hostel Management System is that it is restricted by the capability of the user interface and cannot create extra options unless it is written down in its code which causes delay in the work flow.

IV. Conclusion

In the end, this project has turned out to be a great success from the teams' point of view as we were able to accomplish a lot and will be always working to take it a step ahead. The research done and the problems faced have led us to believe that Hostel Management System will fit into the structure made for hostels and make great improvements to the process of creating and maintaining records efficiently.

References

- [1] <https://www.coursehero.com/file/p3k918r/>
- [2] https://www.veltech.edu.in/hostel-management-system2020_21/index.php
- [3] <https://hostelmanagement.com/>
- [4] 100 Tips for Hoteliers: What Every Successful Hotel Professional Needs to Know and Do

Online Book Rent System

Amandeep Singh, Deepank Jangid, Shresth Bhatiya

*Students, BCA III, Department of Computer Science
St. Xavier's College, Jaipur*

Abstract

Student Book Place (Books Rent Management System) deals with the maintenance of the Book rent details. It works on the principles of renter and borrower. It is maintained on the daily basis of rent request. The faculties will be provided with fulfilment of separate form to validate the identity of borrower. The validation of information done by admin will make the borrower eligible to have the services. Only if the information entered in the form comes out to be true, then only books will be sent. The books rented reports based on weekly and consolidate will be generated. It will serve as time effective tool for generating rental stats for large number of orders. BookPlace (Books Rent Management System) is a website developed for need of books in schools, colleges and institutes and even for leisure. The information is sorted by the admin, which can be provided in particular scenarios. This system will also help student. Books Rent Management System has become important factor in modern time. This system should help the people to streamline their current books buying style. Building this system in web-based interface will further help the ease of accessibility through any web browser.

Keywords: *Book Rent Management system, web-based interface, rental stats.*

I. Introduction

Online Book store is an online web application where the customer can purchase books online. Through a web browser the customers can search for a book by its title or author, later can add to the shopping cart. The user can login using his account details or new customers can set up an account very quickly. They should give the details of their name, contact number and email id. The user can also give feedback to a book by giving ratings on a score of five. The books are divided into many categories based on subject Like Science, Commerce, Math etc.

Key objective of the proposed system includes Economic feasibility, Time Flexibility, Technical feasibility and User-friendly interface

The proposed system has the following functionalities:

A Home page with product catalogue - This is the page where the user will be navigated after a successful login. It will display all the book categories and will have a search keyword option to search for the required book. It also includes some special sections like recommended titles, weekly special books.

Search system - A search by keyword option is provided to the user using a textbox. The keyword to be entered should be the book title.

Advanced Search system - Advanced search helps the user to search for a book based on Title, Author, Category and price range. All the books which match the particular search criteria and their total count will be displayed. From here the user can select a book and add to the shopping cart.

Book Description - If the user would like to know details about a book he can click on the title from where he will be directed to a Book description page. It includes the notes on the book content and also, a link to Amazon.com to get the book review.

Managing user accounts - Each user should have an account to access all the functionalities of website. User can login using login page and logout using the logout page. All the user sessions will be saved in the database.

Administration - The Administrator will be provided with special functionalities like- Add or delete a book category, Add or delete a member, Manage member orders.

Admin Login Form - In the admin login form login credentials information of the admin has to be provided. Any invalid entry will not let admin get logged in.

User Signup Form- any new user can sign up for issuing the book on rent.

II. System Methodology

Data Flow Diagram

The dataflow model represents the process as a set of activities each of which carries out some data transformation. It shows how the input to the process such as specification is transformed to an output such as design. The activities here maybe lower than in a workflow model. They may represent transformations carries out by people or computers. Four notations are used to complete a DFD.

These notations are given below: -

- **Data flow** - The data flow is used to describe the movement of information from one part of the system to another part. Flows represent data in motion. It is a pipe line through which information flows. Data flow is represented by an arrow.



Fig. 1 Arrow – Information flow symbol

- **Function** - A circle or bubble represents a process that transforms incoming data to outgoing data. Process shows a part of the system that transforms inputs to outputs.



Fig. 2 Bubble – Process symbol

- **Input or Output** - A square defines a source or destination of system data. External entities represent any entity that supplies or receive information from the system but is not a part of the system.



Fig. 3 Square – Source/destination symbol

- **Data store** - The data store represents a logical file. A logical file can represent either a data store symbol which can represent either a data structure or a physical file on disk. The data store is used to collect data at rest or a temporary repository of data. It is represented by open rectangle.

0-level DFD:

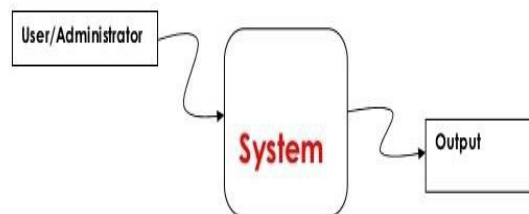

Fig. 4 Zero-level DFD

III. System Design

The analyst actually makes number of designs of the system on paper or on the computer and sees to it that the rough image made of the system comprises of all the requirements or not. Once this is done, the analyst selects and finalizes a best suited design for the development of the system.

Based on the user requirements and the detailed analysis of the existing system, the new system must be designed. This is the phase of system designing. It is the most crucial phase in the developments of a system. The logical system design arrived at as a result of systems analysis is converted into physical system design. Normally, the design proceeds in two stages:

Preliminary or General Design: In the preliminary or general design, the features of the new system are specified. The costs of implementing these features and the benefits to be derived are

estimated. If the project is still considered to be feasible, we move to the detailed design stage.

Structured or Detailed Design: In the detailed design stage, computer-oriented work begins in earnest. At this stage, the design of the system becomes more structured. Structure design is a blueprint of a computer system solution to a given problem having the same components and inter-relationships among the same components as the original problem. Input, output, databases, forms, codification schemes and processing specifications are drawn up in detail

In the design stage, the programming language and the hardware and software platform in which the new system will run are also decided.

Hardware Requirements:

- Pentium Min. 233 MHz
- 32 MB Ram
- 512 KB Cache Memory
- Hard disk 4.3 GB
- Microsoft Compatible 101 or more Key Board

Software Requirements:

Operating System: Windows 7/8/10

Back End: PHP

Front End: HTML, CSS, Java Script

Database Connectivity: MYSQL Database

IV. Results and Discussion

Taxonomy of BookPlace (Books Rent Management System)

- Users of BookPlace are classified into two categories: Admin and Customer.

Administrators -

Administrators are responsible for management of both faculty and order panel.

Customers -

Customers can order as many books as they want in rent so as to efficiently use their time and money.

Existing system -

The Existing system which provides books in rent is not as effective as this since it provides two different panels, admin and customers which make this portal quite easy to use.

Disadvantages of existing system:

Not User Friendly:

The existing system is not a user friendly system, because the retrieval of the data is not possible every time.

Time consuming:

Every work is done manually so we cannot generate report in the middle of the session or as per the requirement because it is very time consuming.

If a user wants to order multiple books then he has to fill the form each time which will consume time.

There are already many such kind of Systems which provides books rental features and they can be downloaded and saved by the users. The limitation of this project is that there is no login for users and the final filled form submitted is the only information given to admin which can be risk prone. An Intranet application can provide much better security

V. Scope

The scope of the project is the system on which the software is installed, i.e., the project is developed as a desktop application, and it will work for a particular institute. But later on, the project can be modified to operate it online.

It can be used by users all around the country. It can help students and scholars a lot.

Scope for Future Prospects-

- Online implementation can be done.
- RFID (Radio Frequency Identification) technology can be used.
- Introduction of messaging and emailing can be added, which may send the attendance details to the students, or more probably their parents. This feature may help in maintaining a good attendance of any institute.

VI. Conclusion

The Book Place (Books Rent Management System) is developed using PHP fully meets the objectives of the system which it has been developed. The system has reached a steady state where all bugs have been eliminated. The system is operated at a high level of efficiency and all the teachers and user associated with the system understands its advantage. The system solves the problem. It was intended to solve as requirement specification. Thus, the Book Place (Books Rent Management System) is reviewed based on the various object-oriented features, advantages and disadvantages, etc and also stated the possible future enhancements that can be made in the Book Place (Books Rent Management System).

References

- [1] www.w3schools.com/in.php.net
- [2] en.wikipedia.org/wiki/PHP
- [3] www.hotscripts.com/category/php/
- [4] www.apache.org/
- [5] www.mysql.com/click.php?e=350

**“The common facts of today are the products
of yesterday’s research”**



Nevta-Mahapura Road, Near Nevta Dam, Tehsil Sanganer, Jaipur-302029



ST. XAVIER'S COLLEGE JAIPUR

Affiliated to the University of Rajasthan

Approved under Section 2(f) and 12(B) of UGC Act, 1956

A Christian Minority Educational Institution under Section 2(g) of NCMEI Act, 2004

Nevta-Mahapura Road, Near Nevta Dam, Tehsil Sanganer, Jaipur-302029

College Website: www.stxaversjaipur.org

Informatica Web page: <https://stxaversjaipur.org/informaticas.aspx>

Contact: 9828726366 , 9680791955

Email: admission@stxaversjaipur.org
